

## LBV

## Angle Drills

- Quiet – Very low noise level.
- Low air consumption – Good operating economy.
- Side exhaust – The air can be directed to suit the operator.
- Rear exhaust – The air is piped away through a pliant hose.
- Lubrication-free – For clean working environment and operator comfort.
- Collet chuck or threaded spindle.
- Multiple lever options.



Model	Free speed r/min	Setting range rpm	Collet or chuck capacity in	Weight lb	Air consumption at free speed cfm	Hose dimension		Air inlet thread NPT	Power hp	Ordering No.
						mm	in			
<b>30° angle head</b>										
LBV11 S029-S30	2900	–	13/64	1.1	8.5	5.0	1/8	1/8	0.16	8421 0108 70
LBV16 032-30	3200	1500-3200	13/64	1.1	18.4	6.3	1/4	1/4	0.4	8421 0110 05
LBV16 032-S30	3200	1500-3200	13/64	1.0	18.4	6.3	1/4	1/4	0.4	8421 0110 04
LBV16 032-32	3200	1500-3200	c	1.1	18.4	6.3	1/4	1/4	0.4	8421 0110 07
LBV16 032-S32	3200	1500-3200	c	1.0	18.4	6.3	1/4	1/4	0.4	8421 0110 06
LBV16 045-30	4500	3200-4500	13/64	1.1	18.4	6.3	1/4	1/4	0.4	8421 0110 71
LBV36 S030-30 <sup>e</sup>	3000	–	13/64	2.2	36.0	10.0	3/8	1/4	0.73	8421 0414 70
<b>45° angle head</b>										
LBV16 032-45	3200	1500-3200	13/64	1.1	18.4	6.3	1/4	1/4	0.4	8421 0110 59
LBV16 032-46	3200	1500-3200	c	1.1	18.4	6.3	1/4	1/4	0.4	8421 0110 60
<b>90° angle head</b>										
LBV11 S029-S90	2900	–	13/64	1.1	8.5	5.0	1/8	1/8	0.16	8421 0109 79
LBV16 032-90	3200	1500-3200	13/64	1.1	18.4	6.3	1/4	1/4	0.4	8421 0110 00
LBV16 032-S90	3200	1500-3200	13/64	1.0	18.4	6.3	1/4	1/4	0.4	8421 0110 01
LBV16 032-92	3200	1500-3200	c	1.1	18.4	6.3	1/4	1/4	0.4	8421 0110 03
LBV16 032-S92	3200	1500-3200	c	1.0	18.4	6.3	1/4	1/4	0.4	8421 0110 02
LBV16 045-90	4500	3200-4500	13/64	1.1	18.4	6.3	1/4	1/4	0.4	8421 0110 20
LBV16 045-92	4500	3200-4500	c	1.1	18.4	6.3	1/4	1/4	0.4	8421 0110 21
LBV16 055-90	5500	4500-5500	13/64	1.1	18.4	6.3	1/4	1/4	0.4	8421 0110 23
LBV16 055-S92	5500	4500-5500	c	1.0	18.4	6.3	1/4	1/4	0.4	8421 0110 58
LBV36 S030-90 <sup>e</sup>	3000	–	13/64	2.2	36.0	10.0	3/8	1/4	0.73	8421 0414 60
LBV36 S030-92 <sup>e</sup>	3000	–	c	2.2	36.0	10.0	3/8	1/4	0.73	8421 0414 64
LBV36 S045-90 <sup>e</sup>	4500	–	13/64	2.2	36.0	10.0	3/8	1/4	0.73	8421 0414 62
<b>360° angle head</b>										
LBV16 032-90Z	3200	1500-3200	13/64	1.1	18.4	6.3	1/4	1/4	0.4	8421 0110 64
LBV16 032-92Z	3200	1500-3200	c	1.1	18.4	6.3	1/4	1/4	0.4	8421 0110 68
<b>90° angle head – large angle head</b>										
LBV16 005-91	500	200-500	1/4	1.2	18.4	6.3	1/4	1/4	0.4	8421 0110 11
LBV16 005-93	500	200-500	c	1.2	18.4	6.3	1/4	1/4	0.4	8421 0110 12
LBV16 010-91	1000	500-1000	1/4	1.2	18.4	6.3	1/4	1/4	0.4	8421 0110 16
LBV16 010-93	1000	500-1000	c	1.2	18.4	6.3	1/4	1/4	0.4	8421 0110 17
LBV16 018-91	1800	800-1800	1/4	1.2	18.4	6.3	1/4	1/4	0.4	8421 0110 18
LBV16 018-93	1800	800-1800	c	1.2	18.4	6.3	1/4	1/4	0.4	8421 0110 19
LBV16 032-91	3200	1500-3200	1/4	1.2	18.4	6.3	1/4	1/4	0.4	8421 0110 09
LBV16 032-93	3200	1500-3200	c	1.2	18.4	6.3	1/4	1/4	0.4	8421 0110 10
LBV16 032-S93	3200	1500-3200	c	1.2	18.4	6.3	1/4	1/4	0.4	8421 0110 39
LBV16 045-91	4500	3200-4500	1/4	1.2	18.4	6.3	1/4	1/4	0.4	8421 0110 38
LBV36 S030-91 <sup>e</sup>	3000	–	1/4	2.2	36.0	10.0	3/8	1/4	0.73	8421 0414 50
LBV36 S060-91 <sup>e</sup>	6000	–	1/4	2.2	36.0	10.0	3/8	1/4	0.73	8421 0414 51
LBV36 S030-93 <sup>e</sup>	3000	–	c	2.2	36.0	10.0	3/8	1/4	0.73	8421 0414 52
LBV36 S060-93 <sup>e</sup>	6000	–	c	2.2	36.0	10.0	3/8	1/4	0.73	8421 0414 53
<b>90° angle head – Key chuck models</b>										
LBV16 018-11	1800	800-1800	5/16	1.7	18.4	6.3	1/4	1/4	0.4	8421 0110 22
LBV34 S005 <sup>b</sup>	500	–	1/2 <sup>a</sup>	4.6	15.9	10.0	3/8	1/4	0.6	8421 0309 04
LBV34 S010 <sup>b</sup>	1000	–	3/8 <sup>a</sup>	4.4	15.9	10.0	3/8	1/4	0.6	8421 0309 12
LBV34 S040 <sup>b</sup>	4000	–	1/4 <sup>a</sup>	3.3	15.9	10.0	3/8	1/4	0.6	8421 0309 46
<b>90° angle head – heavy-duty</b>										
LBV37 030	3000	–	c	2.4	46	10.0	3/8	3/8	1.1	8421 0414 54
LBV37 HD030	3000	–	d	2.4	46	10.0	3/8	3/8	1.1	8421 0414 56

<sup>a</sup> Spindle thread, male 3/8"-24 UNF. <sup>b</sup> Side exhaust. <sup>c</sup> Internal thread 1/4"-28. <sup>d</sup> Internal thread 5/16". <sup>e</sup> Short lever as standard.

## Dimensions

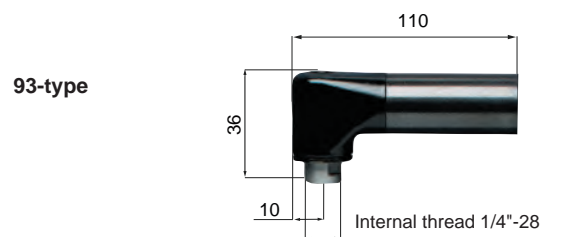
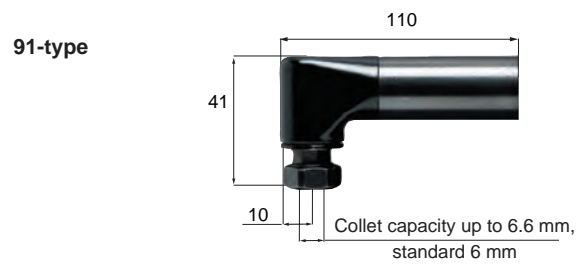
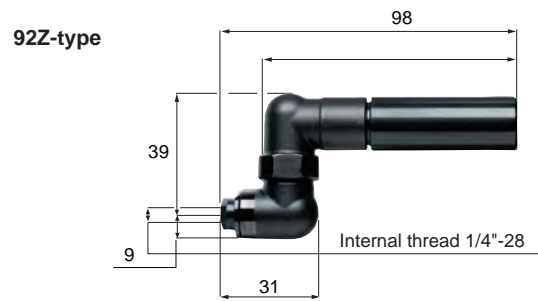
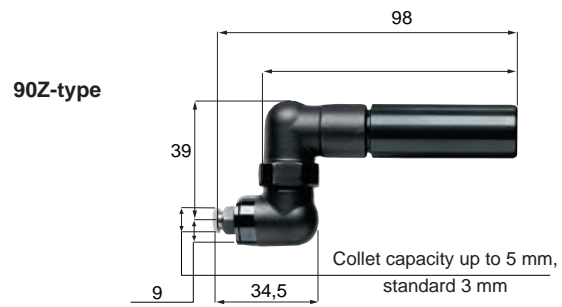
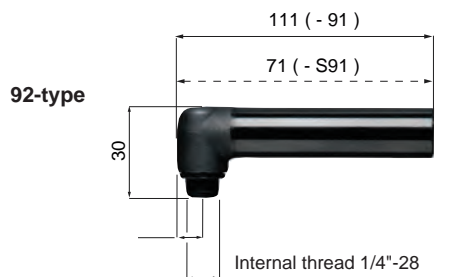
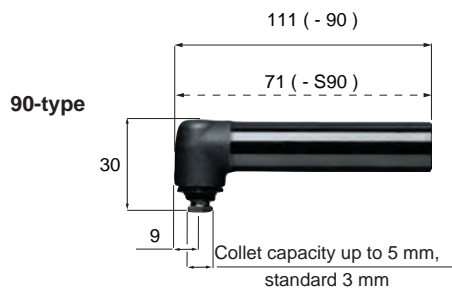
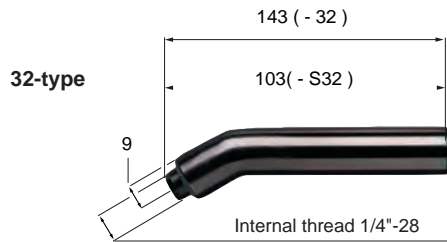
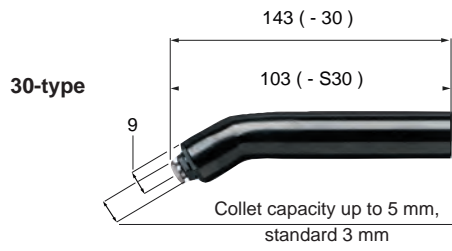

## Dimensions

### DRILLING CAPACITY

Model	Angle head mm				
	A	B	C	L	H
LBV11 S027-S30	59	25	18	224	30
LBV11 S025-S90	44	30	18	204	30
LBV16 032-S30	103	25	17	241	42
LBV16 032-30	143	25	17	281	42
LBV16 032-S32	103	25	17	241	42
LBV16 032-32	143	25	17	281	42
LBV16 032-90	111	30	17	248	42
LBV16 032-S90	71	30	17	209	42
LBV16 032-S92	71	30	17	209	42
LBV16 032-92	111	30	17	249	42
LBV16 032-90Z	145	48	17	283	42
LBV16 032-91	110	39	20	248	42
LBV16 032-93	110	36	20	248	42
LBV16 005-91	110	39	20	248	42
LBV16 005-93	110	36	20	248	42
LBV16 010-91	110	39	20	248	42
LBV16 010-93	110	36	20	248	42
LBV16 018-91	110	39	20	248	42
LBV16 018-93	110	36	20	248	42
LBV34 S040	92	97	20	255	43
LBV34 S010	92	114	20	290	43
LBV34 S005	92	120	20	290	43
LBV36 S030-91	92	41	20	252	43
LBV36 S060-91	92	41	20	252	43
LBV36 S030-93	92	36	20	252	43
LBV36 S060-93	92	36	20	252	43
LBV36 S030-30	122	26	18	281	43
LBV36 S045-30	122	26	18	281	43
LBV36 S030-90	112	30	18	272	43
LBV36 S045-90	112	30	18	272	43
LBV36 S030-92	112	30	18	272	43
LBV37 030	55	39	23	262	43
LBV37 HD030	55	39	23	262	43

LBV11, -16, -36  
30°

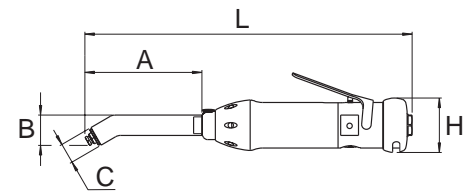

LBV11, -16, -36  
90°

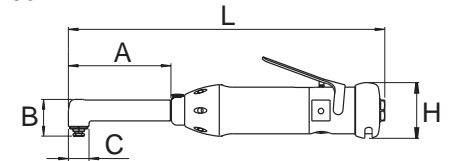

LBV16, -25  
360°

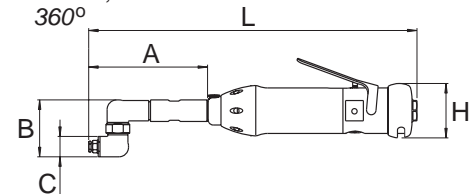

LBV34  
90°

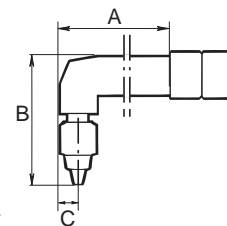

LBV37  
90°

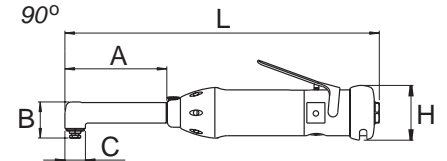

## Accessories Included

### KEY WRENCHES

Collet or chuck with key  
3 mm collet (5.0 collet capacity head)  
6 mm collet (6.6 collet capacity head)

## Optional Accessories

### SAFETY LEVERS

For model	Ordering No.
LBV16	4110 1787 90
LBV36/37	4150 1594 97



Safety lever

## Accessories

## Angle Drills

### SHORT LEVERS

For model	Ordering No.
LBV16	4210 2306 04



Short lever

### COLLETS FOR 5.0 MM CAPACITY HEAD LBV11, LBV16 – (-30, -90, -90Z) AND LBV36 (-30, -90)

Capacity mm	Ordering No.	Capacity mm	Ordering No.	Capacity in	Ordering No.
1.0	4110 0438 01	3.4	4110 0438 33	1/16	4110 0438 19
1.5	4110 0438 02	3.5	4110 0438 13	3/32	4110 0438 20
1.8	4110 0438 28	3.6	4110 0438 24	1/8	4110 0438 21
2.0	4110 0438 03	3.7	4110 0438 34	5/32	4110 0438 22
2.1	4110 0438 29	3.8	4110 0438 14	3/16	4110 0438 23
2.2	4110 0438 04	3.9	4110 0438 35		
2.3	4110 0438 30	4.0	4110 0438 15		
2.4	4110 0438 05	4.1	4110 0438 25		
2.5	4110 0438 06	4.2	4110 0438 26		
2.6	4110 0438 07	4.3	4110 0438 36		
2.7	4110 0438 31	4.4	4110 0438 37		
2.8	4110 0438 32	4.5	4110 0438 16		
2.9	4110 0438 08	4.6	4110 0438 38		
3.0	4110 0438 09	4.7	4110 0438 39		
3.1	4110 0438 10	4.8	4110 0438 18		
3.2	4110 0438 11	4.9	4110 0438 40		
3.3	4110 0438 12	5.0	4110 0438 27		

Collets for 5.0 mm (Thread BSF 9/32 -40)

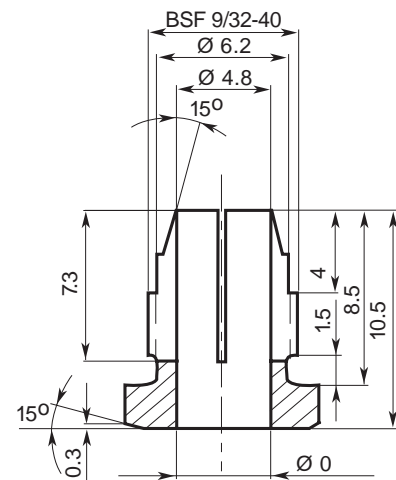

### COLLETS FOR 6.6 MM CAPACITY HEAD LBV16 (-91) AND LBV36 (-91)

Capacity mm	Ordering No.	Capacity mm	Ordering No.
1.6	4110 1411 01	4.2	4110 1411 14
1.8	4110 1411 02	4.4	4110 1411 15
2.0	4110 1411 03	4.6	4110 1411 16
2.2	4110 1411 04	4.8	4110 1411 17
2.4	4110 1411 05	5.0	4110 1411 18
2.6	4110 1411 06	5.2	4110 1411 19
2.8	4110 1411 07	5.4	4110 1411 20
3.0	4110 1411 08	5.6	4110 1411 21
3.2	4110 1411 09	5.8	4110 1411 22
3.4	4110 1411 10	6.0	4110 1411 23
3.6	4110 1411 11	6.2	4110 1411 24
3.8	4110 1411 12	6.4	4110 1411 25
4.0	4110 1411 13	6.6	4110 1411 26

Collets for 6.6 mm

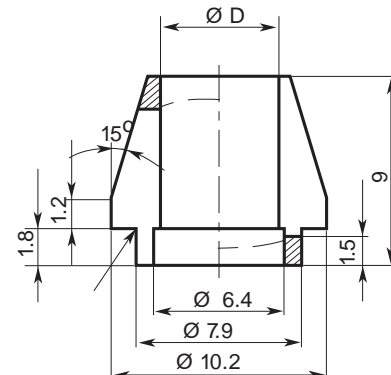

Collet nut 4110 1410 00, to be ordered separately.



## Service Kits

LBV16	4081 0322 90
LBV24	4081 0005 90
LBV25	4081 0272 90
LGB/LBV34	4081 0035 90
LBV36 (30, 90/92)	4081 0263 90
LBV36 (91/93)	4081 0251 90
LBV37	4081 0431 90