

For Depressed Center and Cut-off Wheels

Angle Grinders

No matter which of our vane grinders you choose you will get durable tools with high power and low weight. In addition, vibrations and noise are on a low level.

- LSV19 – For work in cramped spaces, the LSV19 series is small yet powerful, and lubrication free.
Features: Speed governor, sealed angle head, thermally insulated handle and lubrication-free air motor.
- LSV28 – Small, yet powerful giving 1 hp. Available in an extended version for optimal accessibility.
Features: Speed governor and thermally insulated handle.
- LSV38 – If you are looking for the most powerful one-hand grinder on the market, then you have found it – up to 1.7 hp.
Features: Speed governor, sealed angle head, lubrication-free air motor, thermally insulated handle, spindle lock and adjustable wheel guard.
- LSV48 – Our most powerful angle vane grinder with 2.5 hp for ultimate productivity.
Features: Speed governor, sealed angle head, lubrication-free air motor, thermally insulated handle and spindle lock. The autobalancer reduces the vibrations by up to 50%.



Model	Max free speed r/min	Max wheel dia in	Max output hp	Weight lb	Height over spindle in	Air consumption		Spindle thread and length in	Hose size in	Air inlet thread NPT	Ordering No.
						at max output cfm	at free speed cfm				
LSV19 S170-327	17000	3	0.6	1.6	2.8	23	14	UNF 3/8x17	3/8	1/4	8423 0705 80
LSV28 ST13-427E	13000	4	1.0	3.7	3.1	37	16	UNF 3/8x17	3/8	3/8	8423 0706 00
LSV28 ST12-427	12000	4	1.0	3.7	3.2	37	16	UNF 3/8x18	3/8	3/8	8423 0706 01
LSV38 ST12-427	12000	4	1.7	3.5	3.3	58	31	UNF 3/8x17	1/2	3/8	8423 0700 20
LSV38 ST12-527	12000	4 1/2-5	1.7	4.0	3.3	58	31	UNC 5/8x20	1/2	3/8	8423 0700 22
LSV48 SA120-527	12000	5	2.5	5.5	3.9	76	36	UNC 5/8x21	5/8	1/2	8423 0707 53
LSV48 SA085-727	8500	7	2.5	6.2	3.9	76	36	UNC 5/8x21	5/8	1/2	8423 0707 52
LSV48 SA066-727	6600	7	2.5	5.1	3.9	76	36	UNC 5/8x21	5/8	1/2	8423 0707 54

With wheel guard for disc
 -327 = Ø 3"
 -427 = Ø 4"
 -527 = Ø 5" and 4.5"
 -727 = Ø 7"

Selection Guide

HOW TO CHOOSE YOUR LSV38

	LSV38 ST12-427	LSV38 ST12-527
1.7 hp air motor	x	x
Adjustable guard positions	x	x
Lockable spindle	x	x
Side handle	x	x
Size wheel, inch	4	4.5 and 5
Spindle thread, inch	UNF 3/8	UNC 5/8

Accessories

For Depressed Center and Cut-off Wheels

Accessories Included

LSV19

Wheel guard
Flanges
Air hose nipple, clamp
Wrenches
Exhaust hose set

LSV28

Wheel guard
Flanges
Air hose, air hose nipple, clamp
Wrenches
Exhaust hose set

LSV38

Wheel guard
Flanges
Support handle (LSV38 ST-models)
Wrenches
Grease refill

LSV48

Wheel guard
Flanges
Support handle
Wrenches
Grease refill

LSV19

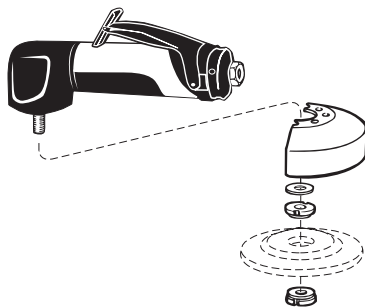

LSV38

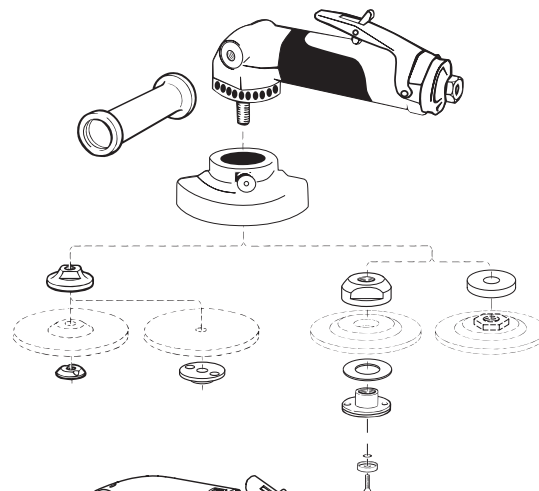

LSV28

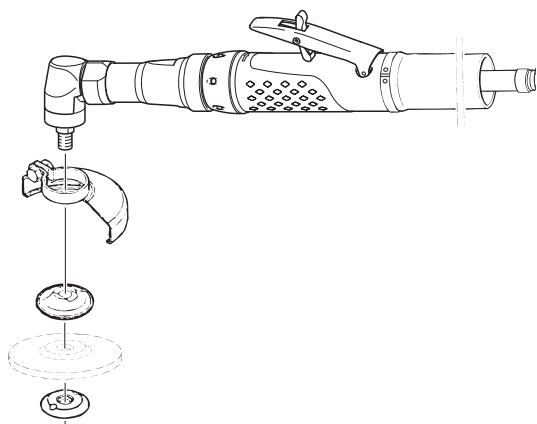

LSV48

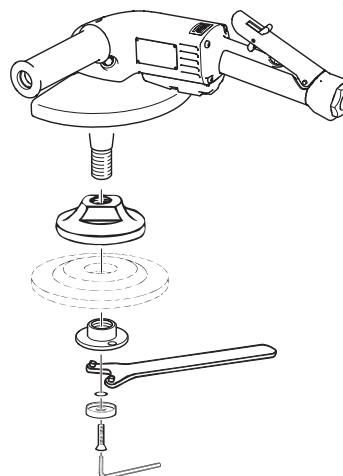

Productivity Kits

Model	Max air flow	Hose 16.4 ft	Coupling	Lubrication	Ordering No.
MIDI Optimizer F/RD EQ10US-T13	65 cfm	Turbo 13	ErgoQIC 10US	Yes	8202 0850 29
MIDI Optimizer F/R EQ10US-T13	65 cfm	Turbo 13	ErgoQIC 10US	No	8202 0850 30
MIDI Optimizer F/RD EQ15US-T16	85 cfm	Turbo 16	ErgoQIC 15US	Yes	8202 0850 31
MAXI F/R EQ15US-T20	140 cfm	Turbo 16	ErgoQIC 15US	No	8202 0850 32
MAXI F/RD EQ15US-T20	140 cfm	Turbo 16	ErgoQIC 15US	Yes	8202 0850 33

NOTE: Tool nipple is not included in the Productivity kit and needs to be order separately together with the tool.



Service Kits

LSV19	4081 0488 90
LSV28	4081 0317 90
LSV38	4081 0309 90
LSV48	4081 0312 90