

IRB 910SC

SCARA



The IRB 910SC (SCARA) is fast, cost-effective and, because it's from ABB, accurate. In designing its Selective Compliance Articulated Robot Arm (SCARA), or IRB 910SC, ABB has delivered a single arm robot capable of operating in a confined footprint. ABB's SCARA is ideal for the Small Parts Assembly, Material Handling and parts inspection.

Variants

With a maximum payload of 6 kg, the IRB 910SC is available in three configurations (IRB 910SC – 3/0.45, IRB 910SC – 3/0.55m, and IRB 910SC – 3/0.65.).

All are modular by design, with different linking arm lengths and have individual reaches of 450 mm, 550 mm and 650 mm, respectively.

All members of the SCARA family are tabletop mountable. IP20 and clean room options are under development.

Applications

ABB's SCARA family is designed for a variety of general-purpose applications such as tray kitting, component placement, machine loading/unloading and assembly.

These applications require fast, repeatable and articulate point-to-point movements such as palletizing, depalletizing, machine loading/unloading and assembly.

ABB's SCARA family is ideal for customers requiring rapid cycle times, high precision and high reliability for their Small Part Assembly applications and for laboratory automation and prescription drug dispensing.

Features

- A Clean Room ISO-5 option is under development
- IP20 protection is under development
- Table top mountable
- Ease of integration
- Custom interfaces
- Modular design

Customer benefits

- Short cycle times which achieved by high speed
- High precision which is achieved by superior motion control Superb reliability due to reuse and standard proven components.

Specification			
Robot version	Reach	Payload	Armload
IRB 910SC-3/0.45	450 mm	Rated: 3 kg Max: 6 kg	Included in the max payload
IRB 910SC-3/0.55	550 mm	Rated: 3 kg Max: 6 kg	Included in the max payload
IRB 910SC-3/0.65	650 mm	Rated: 3 kg Max: 6 kg	Included in the max payload

Performance			
	IRB 910SC-3/0.45	IRB 910SC-3/0.55	IRB 910SC-3/0.65
1 kg picking cycle	0.380 s	0.370 s	0.385 s
Max TCP Velocity	6.2 m/s	6.9 m/s	7.6 m/s
Max TCP Acceleration	65 m/s ²	60 m/s ²	55 m/s ²
Acceleration time 0-1m/s	0.04 s	0.05 s	0.06 s
Axis 3 (Z stroke) down force	250 N	250 N	250 N

Maximum Speed			
Axis 1+ Axis 2	6.13 m/s	6.86 m/s	7.58 m/s
Axis 3	1.02 m/s	1.02 m/s	1.02 m/s
Axis 4	2400 deg/s	2400 deg/s	2400 deg/s

Position Repeatability			
Axis 1 + Axis 2	±0.015 mm	±0.015 mm	±0.015 mm
Axis 3	±0.01 mm	±0.01 mm	±0.01 mm
Axis 4	±0.005 deg	±0.005 deg	±0.005 deg

Electrical connections			
	IRB 910SC-3/0.45	IRB 910SC-3/0.55	IRB 910SC-3/0.65
Supply voltage	200-600 V, 50/60Hz	200-600 V, 50/60Hz	200-600 V, 50/60Hz
Transformer rating	3.0 kVA	3.0 kVA	3.0 kVA
Power consumption	220 W	220 W	220 W

Physical			
	IRB 910SC-3/0.45	IRB 910SC-3/0.55	IRB 910SC-3/0.65
Footprint	160mm x160mm	160mm x160mm	160mm x160mm
Weight	24.5 kg	25 kg	25.5 kg

Movement		
IRB 910SC-3/0.45		
Axis movement	Working range	Max speed
Axis 1 Rotation	±140 deg	415 deg/s
Axis 2 Rotation	±150 deg	659 deg/s
Axis 3 Up/Down	180mm	1.02 m/s
Axis 4 Rotation	±400 deg	2400 deg/s

IRB 910SC-3/0.55		
Axis movement	Working range	Max speed
Axis 1 Rotation	±140 deg	415 deg/s
Axis 2 Rotation	±150 deg	659 deg/s
Axis 3 Up/Down	180mm	1.02 m/s
Axis 4 Rotation	±400 deg	2400 deg/s

IRB 910SC-3/0.65		
Axis movement	Working range	Max speed
Axis 1 Rotation	±140 deg	415 deg/s
Axis 2 Rotation	±150 deg	659 deg/s
Axis 3 Up/Down	180mm	1.02 m/s
Axis 4 Rotation	±400 deg	2400 deg/s

Features	
Integrated signal supply	10 signals on wrist
Integrated air supply	4 air on wrist (5 bar)
Robot mounting	Table
Degree of protection	IP20
Controller	IRC5 Compact

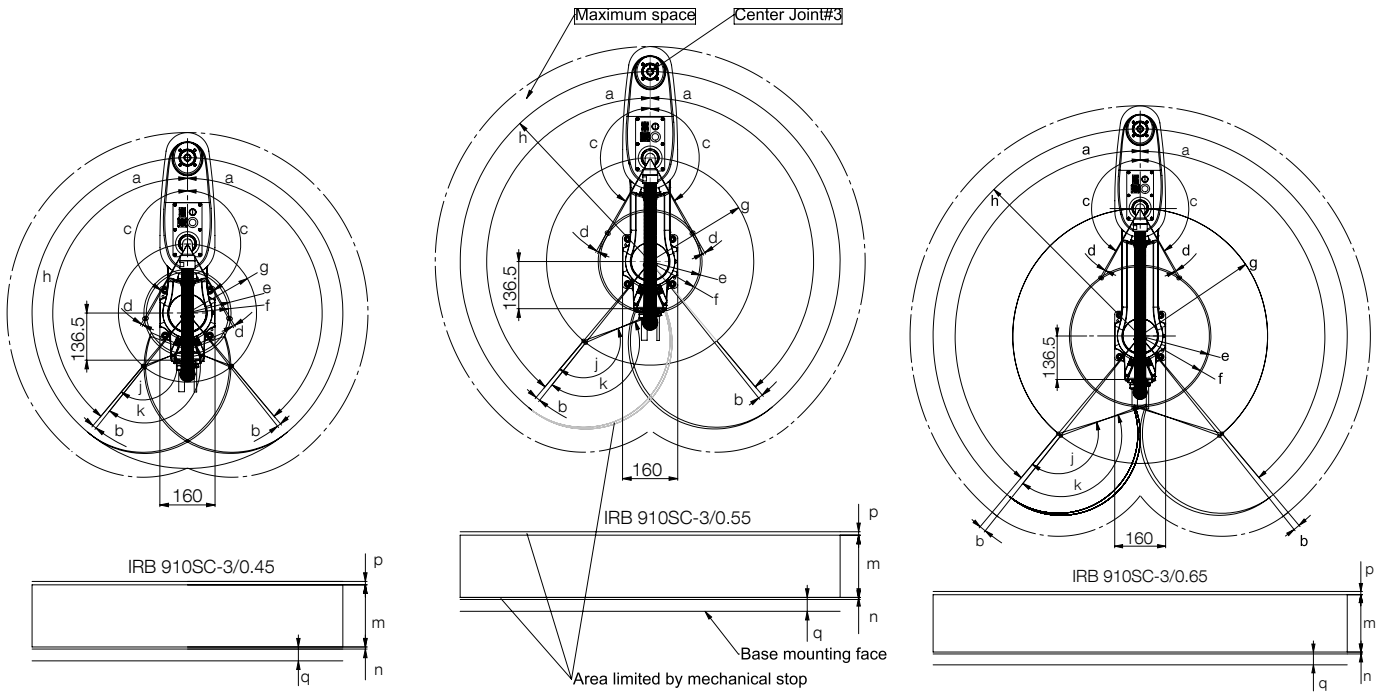

Load Diagram IRB 910SC - 3 / 0.45

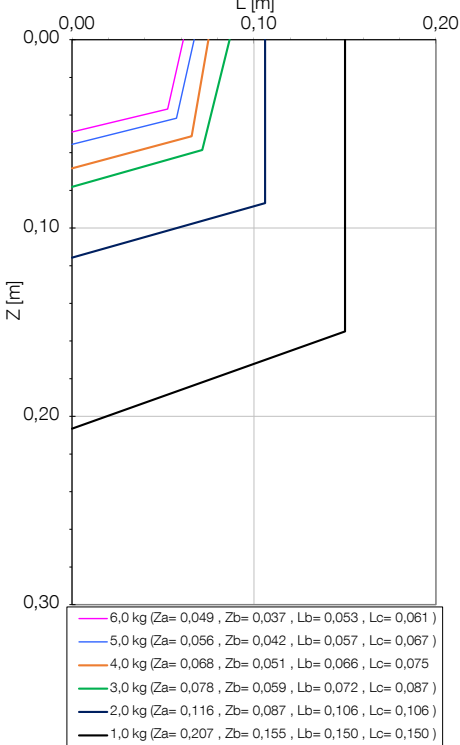

Load Diagram IRB 910SC - 3 / 0.55

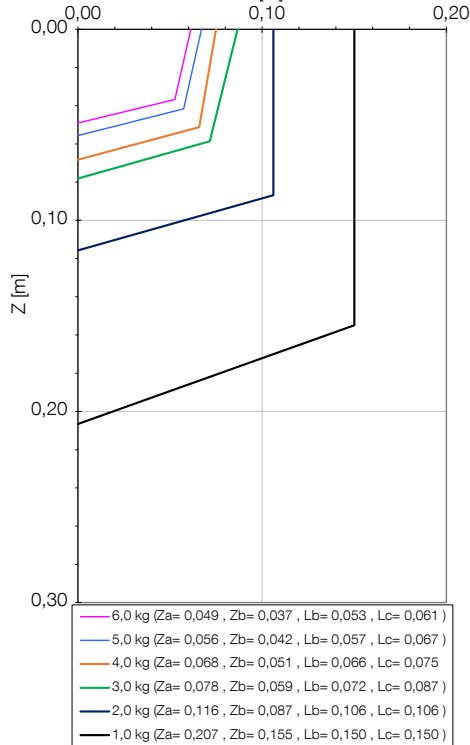

Load Diagram IRB 910SC - 3 / 0.65

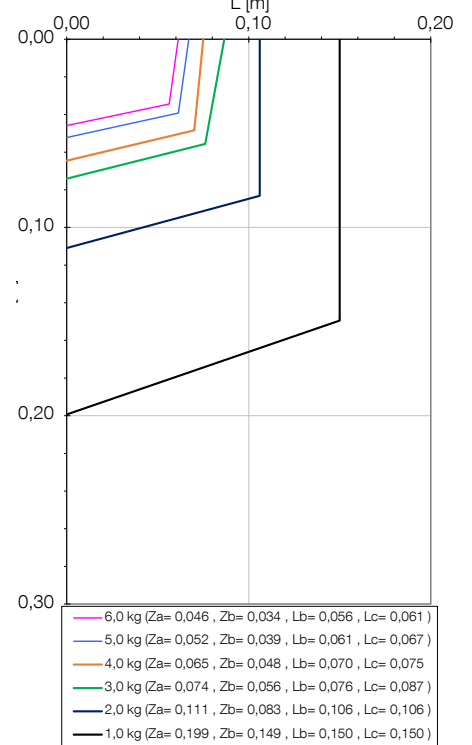

ABB Engineering (Shanghai) Ltd.
Robotics
No. 4528 Kangxin Highway,
Pudong New District
201319, Shanghai, China
Phone: +86 21 6105 6666

abb.com/robotics

We reserve the right to make technical changes or modify the contents of this document without prior notice. With regard to purchase orders, the agreed particulars shall prevail. ABB does not accept any responsibility whatsoever for potential errors or possible lack of information in this document.

We reserve all rights in this document and in the subject matter and illustrations contained therein. Any reproduction, disclosure to third parties or utilization of its contents – in whole or in parts – is forbidden without prior written consent of ABB.
Copyright © 2017 ABB
All rights reserved