

## Low Profile

## Torque Wrenches

Atlas Copco Low Profile Hydraulic Torque Wrenches eliminate problems with tight clearances. There are 6 models to choose from. Repeatability is +/- 1% and output accuracy is at +/- 3%.\*

\* As per NIST standards.



Low profile

Model	Ratchet link hex size		Torque range		Weight		Ordering No.
	mm	in	Nm	ft lb	kg	lb	
RTX-2	19-65	3/4 – 2 3/4	346-2318	255-1710	2	4.5	8434 2021 90
RTX-4	25-85	1 – 3 1/8	786-5226	580-3855	4.4	9.7	8434 2021 95
RTX-8	46-105	1 5/8 – 4 1/8	1549-11049	1143-8151	9	19.5	8434 2022 00
RTX-14	60-135	2 1/2 – 5 3/8	2725-18165	2010-13400	15	33	8434 2116 58
RTX-18	75-140	3 1/2 – 5 1/2	3628-24191	2676-17845	23	51	8434 2022 05
RTX-30	90-165	3 1/2 – 6 1/2	6466-43108	4770-31800	35.5	78	8434 2022 10

## Dimensions

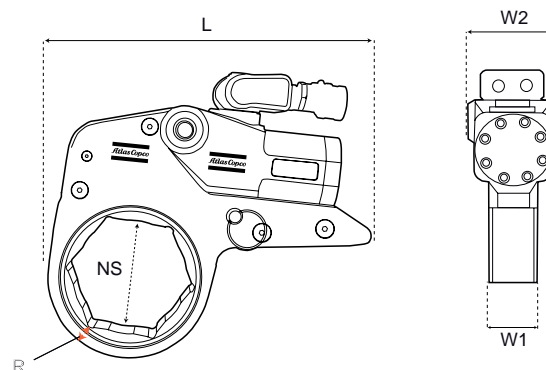

Model	L		NS (based on ratchet link size)		R		W1		W2	
	mm	in	mm	in	mm	in	mm	in	mm	in
RTX-2	183	7.2	19-65	3/4 – 2 9/16	9	0.35	32	1.26	49	1.92
RTX-4	248	9.7	32-80	1 5/16 – 3 1/8	12	0.47	42	1.65	65	2.56
RTX-8	308	12.1	46-100	1 13/16 – 3 7/8	15	0.59	53	2.08	82	3.22
RTX-14	372	14.6	50-120	2 – 4 5/8	18.5	0.72	63	2.48	99	3.89
RTX-18	393	15.5	75-140	3 – 5 1/2	22.2	0.87	70	2.75	111	4.37
RTX-30	457	18	90-155	3 9/16 – 6 1/8	25.4	1	83	3.26	132	5.28

# Torque Wrenches Low Profile

# Accessories

The following is a standard list of ratchet link sizes for use with RTX Powerheads. Whatever the link size, you still only need one torque chart per Powerhead model.



## RTX-02 DIRECT FIT RATCHET LINK SIZES, TORQUE RANGE OF 346 – 2318 NM

Across flat				Across flat				Across flat			
Imperial	Metric	Size	Ordering No.	Imperial	Metric	Size	Ordering No.	Imperial	Metric	Size	Ordering No.
	17	RL02-17MM	8434 2132 41	1	34	RL02-34	8434 2132 81	2"	50.799	RL02-200 RR	8434 2021 74
3/4"	19.05	RL02-012/19MM RR	8434 2132 47	1 3/8"	34.924	RL02-106	8434 2132 17	2 1/16"	52.386	RL02-201	8434 2132 53
3/4"	19.05	RL02-012/19MM	8434 2131 84	1 7/16"	36.511	RL02-107/36MM	8434 2021 68	2 1/8"	53.974	RL02-202	8434 2132 56
13/16"	20.637	RL02-013	8434 2131 87	1 7/16"	36.511	RL02-107/36MM RR	8434 2021 83	2 3/16"	55.561	RL02-203/55MM	8434 2132 59
	22	RL02-22MM	8434 2132 74	1 1/2"	38	RL02-108/38MM	8434 2132 20	2 1/4"	57.149	RL02-204	8434 2132 62
7/8"	22.224	RL02-014	8434 2020 00	1 9/16"	39.686	RL02-109	8434 2132 23		58	RL02-58MM	8434 2132 89
15/16"	23.812	RL02-015	8434 2131 90	1 5/8"	41.274	RL02-110/41MM	8434 2021 07	2 5/16"	58.736	RL02-205	8434 2132 65
	24	RL02-24MM	8434 2020 54	1 5/8"	41.274	RL02-110/41MM RR	8434 2021 08	2 3/8"	60.324	RL02-206/60MM	8434 2021 47
1"	25.339	RL02-100/25MM	8434 2020 03	1 11/16"	43	RL02-111/43MM	8434 2132 26	2 7/16"	61.911	RL02-207	8434 2132 68
1"	25.339	RL02-100/25MM 12PT	8434 2131 93	1 3/4"	44.449	RL02-112	8434 2132 29	2 1/2"	63.498	RL02-208	8434 2132 71
1 1/16"	27	RL02-101/27MM	8434 2131 96	1 13/16"	46	RL02-113/46MM	8434 2132 32	2 9/16"	65	RL02-209/65MM	8434 2021 50
1 1/8"	28.574	RL02-102	8434 2131 99	1 13/16"	46	RL02-113/46MM RR	8434 2132 35	2 5/8"	66.673	RL02-210	8434 2021 51
1 1/8"	28.574	RL02-102 12PT	8434 2132 02	1 7/8"	47.624	RL02-114	8434 2020 06	2 3/4"	69.848	RL02-212	8434 2021 59
1 3/16"	30.162	RL02-103/30MM	8434 2132 05	1 15/16"	49.211	RL02-115	8434 2132 38		70	RL02-212/70MM	8434 2059 29
1 1/4"	31.74	RL02-104/32MM 12PT	8434 2132 11		50	RL02-50MM	8434 2021 86	2 13/16"	71.436	RL02-213 13/16	8434 2021 60
	32	RL02-104/32MM	8434 2132 08	2"	50.799	RL02-200	8434 2132 50	2 15/16"	75	RL02-215/75MM	8434 2132 92
1 5/16"	33.336	RL02-105	8434 2132 14								

## RTX-04 DIRECT FIT RATCHET LINK SIZES, TORQUE RANGE OF 786 – 5226 NM

Across flat				Across flat				Across flat			
Imperial	Metric	Size	Ordering No.	Imperial	Metric	Size	Ordering No.	Imperial	Metric	Size	Ordering No.
	15	RL04-15MM	8434 2133 47	1 13/16"	46	RL04-113/46MM	8434 2021 53	2 9/16"	65	RL04-209/65MM	8434 2133 70
	17	RL04-17MM	8434 2133 48	1 13/16"	46	RL04-113/46MM RR	8434 2116 01	2 5/8"	66.673	RL04-210	8434 2133 73
7/8"	22.224	RL04-014/22MM	8434 2133 19	1 7/8"	47.624	RL04-114	8434 2133 43	2 11/16"	68.261	RL04-211	8434 2133 76
	24	RL04-24MM	8434 2133 93		48	RL04-48MM	8434 2134 27	2 3/4"	69.848	RL04-212/70MM RR	8434 2133 82
1"	25.339	RL04-100/25MM	8434 2133 22	1 15/16"	49.211	RL04-115	8434 2133 46		70	RL04-212/70MM	8434 2021 62
1 1/2"	27	RL04-101/27MM	8434 2020 63		50	RL04-50MM	8434 2134 30		71	RL04-71MM	8434 2021 63
1 1/8"	28.574	RL04-102	8434 2133 23	2"	50.799	RL04-200	8434 2133 49	2 13/16"	71.436	RL04-213	8434 2133 85
1 3/16"	30.162	RL04-103/30MM	8434 2133 25	2 1/16"	52.386	RL04-201	8434 2133 52	2 7/8"	73.024	RL04-214	8434 2133 88
	32	RL04-104/32MM	8434 2020 15	2 1/8"	53.974	RL04-202	8434 2133 55	2 15/16"	75	RL04-215/75MM	8434 2020 21
	32	RL04-104/32MM 12PT	8434 2134 15		54	RL04-54MM	8434 2134 33	3"	76.199	RL04-300	8434 2134 00
1 5/16"	33.336	RL04-105	8434 2133 32		55	RL04-55MM RR	8434 2134 39		77	RL04-77MM	8434 2020 22
1 3/8"	34.924	RL04-106	8434 2133 34	2 3/16"	55.561	RL04-203/55MM	8434 2021 71	3 1/16"	77.788	RL04-301	8434 2134 03
1 7/16"	36.511	RL04-107/36MM	8434 2020 09	2 1/4"	57.149	RL04-204	8434 2133 58	3 1/8"	79.373	RL04-302/79MM	8434 2134 06
1 1/2"	38	RL04-108/38MM 12PT	8434 2133 37		58	RL04-58MM	8434 2134 42		80	RL04-80MM	8434 2134 51
1 1/2"	38	RL04-108/38MM	8434 2133 40	2 5/16"	58.736	RL04-205	8434 2133 61	3 3/16"	80.96	RL04-303	8434 2134 07
1 9/16"	39.686	RL04-109	8434 2133 41	2 3/8"	60.324	RL04-206/60MM	8434 2133 64		85	RL04-85MM	8434 2134 54
1 5/8"	41.274	RL04-110/41MM	8434 2021 35	2 7/16"	61.911	RL04-207	8434 2133 65	3 3/8"	85.725	RL04-306	8434 2134 08
	42	RL04-42MM	8434 2134 24	2 1/2"	63.498	RL04-208	8434 2133 67	3 1/2"	88.9	RL04-308	8434 2134 09
1 11/16"	43	RL04-111/43MM	8434 2020 12		64	RL04-64MM	8434 2134 46	3 3/4"	95	RL04-312/95MM	8434 2059 31
1 3/4"	44.449	RL04-112	8434 2020 60								

## Accessories

## Torque Wrenches Low Profile

**RTX-08 DIRECT FIT RATCHET LINK SIZES, TORQUE RANGE OF 1549 – 11049 NM**

Across flat				Across flat				Across flat			
Imperial	Metric	Size	Ordering No.	Imperial	Metric	Size	Ordering No.	Imperial	Metric	Size	Ordering No.
1 1/8"	28.574	RL08-102	8434 2134 93	63	RL08-63MM	8434 2020 31	3 5/16"	84.138	RL08-305	8434 2020 77	
	36	RL08-36mm	8434 2059 34	2 1/2"	63.498	RL08-208	8434 2135 26	85	RL08-85MM	8434 2021 11	
1 1/2"	38	RL08-108/38MM 12PT	8434 2134 99	2 9/16"	65	RL08-209/65MM	8434 2116 04	3 3/8"	85.723	RL08-306	8434 2021 02
1 5/8"	41.274	RL08-110/41MM	8434 2135 02	2 5/8"	66.673	RL08-210	8434 2135 29	3 1/2"	88.898	RL08-308	8434 2020 74
1 11/16"	43	RL08-111/43MM	8434 2135 08		67	RL08-67MM	8434 2020 32	3 9/16"	90.485	RL08-309/90MM	8434 2135 38
1 13/16"	46	RL08-113/46MM	8434 2020 66		70	RL08-212/70MM	8434 2135 59	3 5/8"	92.075	RL08-310	8434 2020 27
1 7/8"	47.624	RL08-114	8434 2135 11		71	RL08-71MM	8434 2135 62	3 3/4"	95	RL08-312/95MM	8434 2135 41
	50	RL08-50MM	8434 2135 47	2 13/16"	71.436	RL08-213	8434 2135 32	3 7/8"	98.423	RL08-314	8434 2021 65
2"	50.799	RL08-200	8434 2020 68		75	RL08-215/75MM	8434 2135 65	1"	100	RL08-315/100MM	8434 2020 24
2"	50.799	RL08-200 12PT	8434 2020 67	3"	76.199	RL08-300	8434 2135 35	4"	101.6	RL08-400	8434 2135 44
2 1/16"	52.386	RL08-201	8434 2135 17		77	RL08-77MM	8434 2135 68	4 1/16"	103.18	RL08-401	8434 2020 75
	54	RL08-54MM	8434 2135 50		78	RL08-78MM	8434 2135 71		105	RL08-105MM	8434 2134 96
2 3/16"	55.561	RL08-203/55MM	8434 2020 69	3 1/8"	79.373	RL08-302	8434 2020 72	4 1/4"	107.95	RL08-404	8434 2020 78
2 1/4"	57.149	RL08-204	8434 2135 20		80	RL08-80MM	8434 2135 74		110	RL08-110MM	8434 2135 05
2 3/8"	60.324	RL08-206/60MM	8434 2020 70	3 1/4"	82.548	RL08-304	8434 2020 73		115	RL08-115MM	8434 2135 14
2 7/16"	61.911	RL08-207	8434 2135 23								

**RTX-14 DIRECT FIT RATCHET LINK SIZES, TORQUE RANGE OF 2725 – 18165 NM**

Across flat				Across flat				Across flat			
Imperial	Metric	Size	Ordering No.	Imperial	Metric	Size	Ordering No.	Imperial	Metric	Size	Ordering No.
1 1/4"	31.74	RL14-104/32MM	8434 2135 99	77	RL14-77MM	8434 2021 30	4"	101.6	RL14-400	8434 2136 43	
1 1/2"	38	RL14-108/38MM	8434 2136 02	3 1/16"	77.788	RL14-301	8434 2136 28	4 1/16"	103.18	RL14-401	8434 2021 26
2"	50.799	RL14-200	8434 2020 33	3 1/8"	79.373	RL14-302	8434 2136 31	4 1/8"	104.78	RL14-402	8434 2136 46
2 3/16"	55.561	RL14-203/55MM	8434 2020 36		80	RL14-80MM	8434 2021 20		105	RL14-105MM	8434 2135 98
	57	RL14-57MM	8434 2136 60	3 3/16"	80.96	RL14-303	8434 2136 32	4 3/16"	106.36	RL14-403	8434 2136 47
2 1/4"	57.149	RL14-204	8434 2020 37	3 1/4"	82.548	RL14-304	8434 2136 30	4 1/4"	107.95	RL14-404	8434 2020 84
2 3/8"	60.324	RL14-206/60MM	8434 2136 13		85	RL14-85MM	8434 2021 32	4 5/16"	109.54	RL14-405	8434 2020 83
2 1/2"	63.498	RL14-208	8434 2136 16	3 3/8"	85.723	RL14-306	8434 2136 33		110	RL14-110MM	8434 2136 01
2 9/16"	65	RL14-209/65MM	8434 2020 39	3 1/2"	88.898	RL14-308	8434 2136 34	4 1/2"	114.3	RL14-408	8434 2136 49
2 5/8"	66.673	RL14-210	8434 2136 19	3 9/16"	90.485	RL14-309/90MM	8434 2136 37		115	RL14-115MM	8434 2136 04
	67	RL14-67MM	8434 2136 64	3 5/8"	92.075	RL14-310	8434 2136 38	4 9/16"	115.89	RL14-409	8434 2136 52
2 11/16"	68.261	RL14-211	8434 2136 20	3 11/16"	93.663	RL14-311	8434 2136 39	4 5/8"	117.48	RL14-410	8434 2136 55
	70	RL14-212/70MM	8434 2136 66	3 3/4"	95	RL14-312/95MM	8434 2020 42		120	RL14-120MM	8434 2136 07
	71	RL14-71MM	8434 2136 67		98	RL14-98MM	8434 2136 70	5"	127	RL14-500	8434 2021 41
2 13/16"	71.436	RL14-213	8434 2136 22	3 7/8"	98.423	RL14-314	8434 2020 45		130	RL14-130MM	8434 2136 10
	75	RL14-215/75MM	8434 2021 29		100	RL14-100MM	8434 2021 14	5 3/8"	136.53	RL14-506	8434 2136 58
3"	76.199	RL14-300	8434 2136 25								

**RTX-18 DIRECT FIT RATCHET LINK SIZES, TORQUE RANGE OF 3628 – 24191 NM**

Across flat				Across flat				Across flat			
Imperial	Metric	Size	Ordering No.	Imperial	Metric	Size	Ordering No.	Imperial	Metric	Size	Ordering No.
1 5/16"	33.336	RL18-105	8434 2020 91	3 3/8"	85.723	RL18-306	8434 2020 85	4 5/8"	117.47	RL18-410	8434 2020 93
1 3/8"	34.924	RL18-106	8434 2020 92	3 1/2"	88.898	RL18-308	8434 2020 87		120	RL18-120MM	8434 2137 00
2 3/16"	55.561	RL18-203/55MM	8434 2137 10		90	RL18-90MM	8434 2137 24	5"	127	RL18-500	8434 2021 56
2 3/8"	60.324	RL18-206/60MM	8434 2137 11	3 9/16"	90.485	RL18-309/90MM	8434 2020 86		130	RL18-130MM	8434 2137 03
2 9/16"	65	RL18-209/65MM	8434 2137 12	3 3/4"	95	RL18-312/95MM	8434 2020 90		135	RL18-135MM	8434 2137 06
2 3/4"	69.85	RL18-212/70MM	8434 2059 47	3 7/8"	98.423	RL18-314	8434 2137 15	5 3/8"	136.52	RL18-506	8434 2021 23
	71	RL18-71MM	8434 2137 14		100	RL18-315/100MM	8434 2020 88		140	RL18-140MM	8434 2020 89
	75	RL18-215/75MM	8434 2137 16	4 1/16"	103.18	RL18-401	8434 2020 47	5 5/8"	142.88	RL18-510	8434 2021 22
3"	76.199	RL18-300	8434 2137 13		105	RL18-105MM	8434 2136 88		145	RL18-145MM	8434 2020 94
	77	RL18-77MM	8434 2137 17		106	RL18-106MM	8434 2136 91	5 3/4"	146.05	RL18-512	8434 2020 96
3 1/8"	79.373	RL18-302	8434 2137 08	4 1/4"	107.95	RL18-404	8434 2020 48	5 15/16"	150.81	RL18-515	8434 2021 24
	80	RL18-80MM	8434 2137 18		110	RL18-110MM	8434 2136 94		151	RL18-151MM	8434 2137 09
	85	RL18-85MM	8434 2137 21		115	RL18-115MM	8434 2136 97	6 1/8"	155.58	RL18-602	8434 2021 25

# Torque Wrenches Low Profile

# Accessories

## RTL-30 DIRECT FIT RATCHET LINK SIZES, TORQUE RANGE OF 6466 – 43108 NM

Across flat				Across flat				Across flat			
Imperial	Metric	Size	Ordering No.	Imperial	Metric	Size	Ordering No.	Imperial	Metric	Size	Ordering No.
2 9/16"	65	RL30-209/65MM	8434 2137 72	4 1/4"	107.948	RL30-404	8434 2137 90		140	RL30-140MM	8434 2138 21
2 15/16"	74.611	RL30-215/75MM	8434 2137 73		110	RL30-110MM	8434 2137 39		145	RL30-145MM	8434 2137 57
3 1/8"	79.373	RL30-302	8434 2137 75	4 1/2"	114.3	RL30-408	8434 2021 01	5 3/4"	146.05	RL30-512	8434 2137 93
	80	RL30-80MM	8434 2138 14		115	RL30-115MM	8434 2137 42		150	RL30-150MM	8434 2137 60
	85	RL30-85MM	8434 2138 17		117	RL30-117MM	8434 2020 56	5 15/16"	150.812	RL30-515	8434 2137 96
3 3/8"	85.723	RL30-306	8434 2137 78	4 5/8"	117.475	RL30-410	8434 2021 00		152	RL30-152MM	8434 2020 61
3 1/2"	88.898	RL30-308	8434 2137 81		120	RL30-120MM	8434 2137 45	6"	152.4	RL30-600	8434 2138 02
	90	RL30-90MM	8434 2138 18		123	RL30-123MM	8434 2137 48		155	RL30-155MM	8434 2137 63
3 3/4"	95	RL30-312/95MM	8434 2137 84		124	RL30-124MM	8434 2020 55	6 1/8"	155.575	RL30-602	8434 2020 59
	98	RL30-98MM	8434 2138 20		125	RL30-125MM	8434 2137 51		160	RL30-160MM	8434 2137 66
3 7/8"	98.423	RL30-314	8434 2137 87	5"	126.998	RL30-500	8434 2020 99	6 3/8"	161.925	RL30-606	8434 2138 05
	100	RL30-315/100MM	8434 2137 33		130	RL30-130MM	8434 2020 53	6 1/2"	165.1	RL30-608	8434 2138 08
4"	101.6	RL30-400	8434 2133 86		133	RL30-133MM	8434 2020 58		170	RL30-170MM	8434 2137 69
4 1/16"	103.18	RL30-401	8434 2137 88		135	RL30-135MM	8434 2137 54		175	RL30-175MM	8434 2138 22
4 1/8"	104.775	RL30-402	8434 2137 89	5 3/8"	136.522	RL30-506	8434 2020 51	7 1/16"	179.387	RL30-701	8434 2138 11
	105	RL30-105MM	8434 2137 36	5 1/2"	139.7	RL30-508	8434 2137 92				



Insert hex

## INSERT HEX, REDUCER FOR RATCHET LINKS

Model	Starting size	Reduces to	Ordering No.	Model	Starting size	Reduces to	Ordering No.
RL02-INS-108/105	1 1/2	1 5/16	4222 2133 93	RL04-INS-302/206	3 1/8	2 3/8	4222 2138 25
RL02-INS-204/105	2 1/4	1 5/16	4222 2133 96	RL04-INS-50/19	50 mm	19 mm	4222 2138 28
RL02-INS-204/108	2 1/4	1 1/2	4222 2133 99	RL04-INS-50/32	50 mm	32 mm	4222 2138 31
RL02-INS-204/114	2 1/4	1 7/8	4222 2134 02	RL04-INS-50/41	50 mm	41 mm	4222 2138 34
RL02-INS-212/103	2 3/4	1 3/16	4222 2134 05	RL04-INS-50/42	50 mm	42 mm	4222 2138 37
RL02-INS-212/107	2 3/4	1 7/16	4222 2134 08	RL04-INS-50/46	50 mm	46 mm	4222 2138 40
RL02-INS-212/108	2 3/4	1 1/2	4222 2134 11	RL04-INS-55/50	55 mm	50 mm	4222 2138 43
RL02-INS-212/109	2 3/4	1 9/16	4222 2134 14	RL04-INS-65/55	65 mm	55 mm	4222 2119 74
RL02-INS-212/110	2 3/4	1 5/8	4222 2134 17	RL04-INS-70/60	70 mm	60 mm	4222 2119 78
RL02-INS-212/113	2 3/4	1 13/16	4222 2134 20	RL04-INS-70/65	70 mm	65 mm	4222 2119 82
RL02-INS-212/114	2 3/4	1 7/8	4222 2134 23	RL08-INS-100MM/80MM	100 mm	80 mm	4222 2140 62
RL02-INS-46/36	46 mm	36 mm	4222 2134 26	RL08-INS-203/200	2 3/16	2	4222 2140 65
RL02-INS-50/41	50 mm	41 mm	4222 2134 29	RL08-INS-302/215	3 1/8	2 15/16	4222 2140 68
RL02-INS-50/46	50 mm	46 mm	4222 2134 32	RL08-INS-302/50MM	3 1/8	50 mm	4222 2140 71
RL04-INS-113/30MM	1 13/16	30 mm	4222 2119 58	RL08-INS-302/55MM	3 1/8	55 mm	4222 2140 74
RL04-INS-113/36MM	1 13/16	36 mm	4222 2119 62	RL08-INS-302/60MM	3 1/8	60 mm	4222 2140 77
RL04-INS-113/42MM	1 13/16	42 mm	4222 2119 66	RL08-INS-314/308	3 7/8	3 1/2	4222 2140 80
RL04-INS-200/112	2	1 3/4	4222 2137 74	RL08-INS-60/50	60 mm	50 mm	4222 2122 07
RL04-INS-200/113	2	1 13/16	4222 2137 77	RL08-INS-60/55	60 mm	55 mm	4222 2122 11
RL04-INS-204/105	2 1/4	1 5/16	4222 2137 80	RL08-INS-70/46	70 mm	46 mm	4222 2140 83
RL04-INS-204/108	2 1/4	1 1/2	4222 2137 83	RL08-INS-70/55	70 mm	55 mm	4222 2140 86
RL04-INS-204/114	2 1/4	1 7/8	4222 2137 86	RL08-INS-70/65	70 mm	65 mm	4222 2140 89
RL04-INS-208/114	2 1/2	1 7/8	4222 2119 70	RL08-INS-80/50	80 mm	50 mm	4222 2140 92
RL04-INS-212/ 208	2 3/4	2 1/2	4222 2137 89	RL08-INS-80/55	80 mm	55 mm	4222 2140 95
RL04-INS-212/201	2 3/4	2 1/16	4222 2137 92	RL08-INS-80/65	80 mm	65 mm	4222 2140 98
RL04-INS-212/202	2 3/4	2 1/8	4222 2137 95	RL08-INS-80/75	80 mm	75 mm	4222 2141 01
RL04-INS-212/203	2 3/4	2 3/16	4222 2137 98	RL08-INS-95/80	95 mm	80 mm	4222 2141 04
RL04-INS-212/204	2 3/4	2 1/4	4222 2138 01	RL14-INS-314/308	3 7/8	3 1/2	4222 2143 38
RL04-INS-212/206	2 3/4	2 3/8	4222 2138 04	RL14-INS-410/314	4 5/8	3 7/8	4222 2143 41
RL04-INS-215/209	2 15/16	2 9/16	4222 2138 07	RL14-INS-410/404	4 5/8	4 1/4	4222 2143 44
RL04-INS-302/100	3 1/8	1	4222 2138 10	RL18-INS-135/123	135 mm	123 mm	4222 2144 13
RL04-INS-302/108	3 1/8	1 1/2	4222 2138 13	RL18-INS-151/143	151 mm	143 mm	4222 2144 16
RL04-INS-302/110	3 1/8	1 5/8	4222 2138 16	RL18-INS-410/308	4 5/8	3 1/2	4222 2144 19
RL04-INS-302/112	3 1/8	1 3/4	4222 2138 19	RL18-INS-410/312	4 5/8	3 3/4	4222 2144 22
RL04-INS-302/200	3 1/8	2	4222 2138 22	RL30-INS-602/600	6 1/8	6	4222 2145 48

## Accessories

### ON SIDE REACTION ARM

Model	Ordering No.
RTX02-14	4222 2107 14
RTX04-14	4222 2109 27
RTX08-14	4222 2110 44
RTX14-14	4222 2141 22
RTX18-14	4222 2141 23
RTX30-14	4222 2144 43

### ALCO REACTION ARM

Model	Ordering No.
RTX02-ALC	8434 2057 58
RTX04-ALC	8434 2057 60
RTX08-ALC	8434 2057 62
RTX14-ALC	8434 2057 64
RTX18-ALC	8434 2057 66
RTX30-ALC	8434 2057 67



On side reaction arm



Alco reaction arm

### BACKUP WRENCH

Atlas Copco Backup Wrenches works in conjunction with any Atlas Copco bolting tool and prevents the nut from rotating. The wrench is made of high strength steel and has a minimum of moving parts. This gives the tool a very long working lifetime without significant wear. Available in any nut size.

Model	Ordering No.	Model	Ordering No.
BK-206	8434 2056 36	BK-500	8434 2056 54
BK-113	8434 2056 30	BK-105MM	8434 2128 93
BK-30MM	8434 2129 26	BK-202	8434 2129 14
BK-200	8434 2056 32	BK-43mm	8434 2129 33
BK-36MM	8434 2129 32	BK-404	8434 2129 38
BK-110	8434 2056 28	BK-013 13/16IN	8434 2128 88
BK-203	8434 2056 34	BK-011 11/16IN	8434 2128 89
BK-209	8434 2056 38	3/4 IN BK-012	8434 2128 97
BK-215	8434 2056 44	15/16IN BK-015	8434 2128 98
BK-302	8434 2056 46	BK-237	8434 2129 20
BK-104=32MM	8434 2128 90	1 1/8IN BK-102	8434 2129 55
BK-308=90MM	8434 2056 48	1 11/16IN BK-111	8434 2129 57
BK-107	8434 2056 26	2 13/16IN BK-213	8434 2129 58
BK-212	8434 2056 42	2 7/8IN BK-214	8434 2056 45
BK-314	8434 2056 50	BK-308=90MM	8434 2056 51
BK-312	8434 2129 29	BK-506	8434 2056 56
BK-210	8434 2056 40	BK-55MM	8434 2128 92
BK-204	8434 2129 17	BK-110MM	8434 2128 99
BK-100MM	8434 2056 24	BK-112	8434 2129 02
BK-302=80MM	8434 2056 53	BK-120MM	8434 2129 08
BK-75MM	8434 2056 55	BK-101/27MM 101/27MM	8434 2129 21
BK-201	8434 2129 11	BK-85MM	8434 2129 44
BK-24MM	8434 2056 23	1 1/8IN BK-102	8434 2129 50
BK-101 1-1/16IN	8434 2056 29	1 11/16IN BK-111	8434 2129 51
1 5/16IN BK-105	8434 2056 31	2 13/16IN BK-213	8434 2129 52
BK-34MM	8434 2128 91	BK-205	8434 2128 70
2 7/16IN BK-207	8434 2128 95	BK-208	8434 2128 71
BK-108	8434 2128 96	BK-211	8434 2128 73
BK-114	8434 2129 05	BK-301	8434 2128 74
BK-300	8434 2129 23	BK-304	8434 2128 76
BK-402	8434 2129 35	BK-306	8434 2128 77
BK-70MM	8434 2129 41	BK-310	8434 2128 67
BK-014 7/8IN	8434 2056 27	BK-400	8434 2128 68
BK-410	8434 2056 52		



Backup wrench

## Torque Wrenches

# Torque Wrenches

# Accessories

## HYDRAULIC TORQUE WRENCH PUMPS

Atlas Copco Hydraulic Torque Wrench Pumps are designed for all hydraulic torque wrench applications. Our pumps are variable piston models with the smallest ratio weight/oil flow on the market.

The pumps are available in two versions: air driven, or electric driven, 110V or 220V. They come in three sizes: small, medium and large.



## AIR DRIVEN HYDRAULIC TORQUE WRENCH PUMPS

Model	Weight		Oil capacity		Intercooler system	Oil flow						Ports	Ordering No.
	kg	lb	liters	gallons		86 bar/ 1250 psi		250 bar/ 3600 psi		700 bar/ 10000 psi			
Panther A110 Small frame	15	33	1.89	0.5	yes	4.5	275	1.1	67	0.4	24	1	8434 2040 19
Panther A110 Full frame	15	33	1.89	0.5	yes	4.5	275	1.1	67	0.4	24	1	8434 2040 17
Panther A380	22	48	5.67	1.5	yes	11.5	701	3.5	213	1.3	79	4	8434 2056 22
TigAir	34	75	9.5	2.5	yes	-	-	-	-	1.1	72	1	8434 2059 62

## Dimensions

Model	Length		Width		Height	
	mm	inches	mm	inches	mm	inches
Panther A110 Small frame	340.3	13.4	347.9	13.7	419.1	16.5
Panther A110 Full frame	340.3	13.4	347.9	13.7	419.1	16.5
Panther A380	398.7	15.7	378.4	14.9	459.7	18.1
TigAir	457.2	18	266.7	10.5	439.9	18.5

## ELECTRIC DRIVEN HYDRAULIC TORQUE WRENCH PUMPS (100V / 220V)

Model	Oil flow						Ports	Ordering No.
	86 bar/ 1250 psi		250 bar/ 3600 psi		700 bar/ 10000 psi			
Panther 025 with handle 110V	3.2	195	0.9	54	0.35	21	1	8434 2040 31
Panther 025 with full frame 110V	3.2	195	0.9	54	0.35	21	1	8434 2040 33
Panther 025 with handle 220V	3.2	195	0.9	54	0.35	21	1	8434 2130 22
Panther 025 with full frame 220V	3.2	195	0.9	54	0.35	21	1	8434 2059 54
Panther 055 110V	6.4	391	1.8	110	0.7	42	4	8434 2040 35
Panther 055 220V	6.4	391	1.8	110	0.7	42	4	8434 2040 37
Lynx 110V	-	-	-	-	0.9	56	1	8434 2059 61
Lynx 220V	-	-	-	-	0.9	56	1	8434 2059 59
Panther 150 110V	10.5	641	2.5	153	1.5	92	4	8434 2040 39
Panther 150 220V	10.5	641	2.5	153	1.5	92	4	8434 2040 41

## Accessories

### HOSES

Non-conductive, twin-line hoses are extremely safe, featuring a 4:1 safety ratio and safety hose burst guards. Batch numbers are printed directly on the hose for traceability.

- 700 bar / 10000 psi.
- Couplers and nipples included.

Model	Description	Ordering No.
90172	4.5 m / 15 ft	8434 2050 08
090172-7	7 m / 22.9 ft	8434 2123 95
090172-10	10 m / 32 ft	8434 2123 74
090172-15	15 m / 49.2 ft	8434 2050 10
090172-20	20 m / 65.6 ft	8434 2123 83



Hose

### CALIBRATED GAUGES

Our gauges are calibrated and have class 1 accuracy. An accurate pressure reading contributes to accurate torquing values.

Model	Description	Ordering No.
090233-2	Gauge 70Mpa back mounted	8434 2124 07
090233-1	Gauge 700 bar-10,000 psi	8434 2051 59



Gauge

### MANIFOLD KIT

Model	Description	Ordering No.
Lynx and TigAir	4-port	8434 2115 73

### COUPLINGS

Couplings are available in standard or quick connect versions.

Model	Description	Ordering No.
090156-1	1/8" Male coupler <sup>a</sup>	8434 2050 06
90156	1/4" Male coupler <sup>b</sup>	8434 2123 41
90157	3/8" Female coupler	8434 2123 44
090155-1	1/8" Male nipple <sup>a</sup>	8434 2123 65
QC-COUPPLERS	Quick connect coupler set	8434 2131 36
90101	Nipple male-male 1/4INx1/4IN	8434 2050 00
90103	Nipple male 1/4INx1/8IN	8434 2050 02
90135	Nipple NPT 1/4INx1/4IN	8434 2050 04
90155	1/4" Male female nipple	8434 2123 38
090155-M	1/4" Male nipple <sup>b</sup>	8434 2123 68

<sup>a</sup> Standard item on RT-0.5, RT-01, RTX-02

<sup>b</sup> Standard item on all RT& RTX tools except RT-0.5, RT-01, RTX-02

### HYDRAULIC OIL

Hydraulic oil for use in our high quality pumps. Comes in 5L (1.32G) container.

Model	Description	Ordering No.
Tellus 46	5 l / 1.32 g container	8434 2040 45



Hydraulic oil