

THRU-ARM CABLE AND HOSE ROUTING

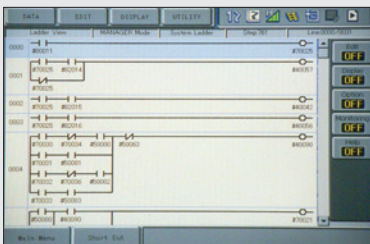

LADDER EDITOR

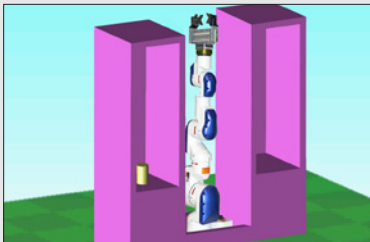

SMALL FOOTPRINT

TOP REASONS TO BUY

- Slim, 7-axis design optimizes space; provides “human-like” flexibility and range of motion, even in tight spaces
- Mounts virtually anywhere in any orientation
- Can be used in environments that are hazardous to humans
- Labor savings justifies capital investment

SIA10D

ASSEMBLY • INJECTION MOLDING • INSPECTION
MACHINE TENDING • PACKAGING • PART TRANSFER

Payload: 10 kg



Compact, Lean and Powerful Arm

- 7-axis actuator-based design and best-in-class wrist performance characteristics provide amazing freedom of movement, coupled with ability to maneuver in very tight areas.
- Superior dexterity enables robot to reorient elbow(s) without affecting hand position or causing self-interference.
- Agile, versatile robot opens up a wide range of industrial applications to robots: ideal for assembly, injection molding, inspection, machine tending and a host of other operations.
- 10 kg payload; 1,203 mm vertical reach; 720 mm horizontal reach; ± 0.1 mm repeatability.
- Slim, compact and powerful – robot can straighten vertically to take up only one square foot of floorspace and is only 264 mm (10.4") wide at widest point.
- Short axis lengths and extreme motion flexibility allow slim manipulator to be positioned out of normal working area (i.e. floor-, ceiling-, wall-, incline- or machine-mounted) without limiting motion range of any axis.

- Mounting SIA10D robot between two machine tools provides open access to machines for fixture maintenance, adjustment or testing.
- Operator has clear access to machine operator station for entering offsets, maintenance or other operations.

DX100 Controller

- Patented multiple robot control supports up to 8 robots/72 axes.
- Windows® CE programming pendant with color touch screen and USB interface.
- Faster processing speeds for smoother interpolation. Quicker I/O response. Accelerated Ethernet communication.
- Extensive I/O suite includes integral PLC and touch screen HMI, 2,048 I/O and graphical ladder editor.
- Supports all major fieldbus networks, including EtherNet/IP, DeviceNet, Profibus-DP and many others.
- Compliant to ANSI/RIA R15.06-1999 and other relevant ISO and CSA safety standards. Optional Category 3 functional safety unit.

SIA10D ROBOT

All dimensions are metric (mm) and for reference only. Please request detail drawings for all design/engineering requirements.

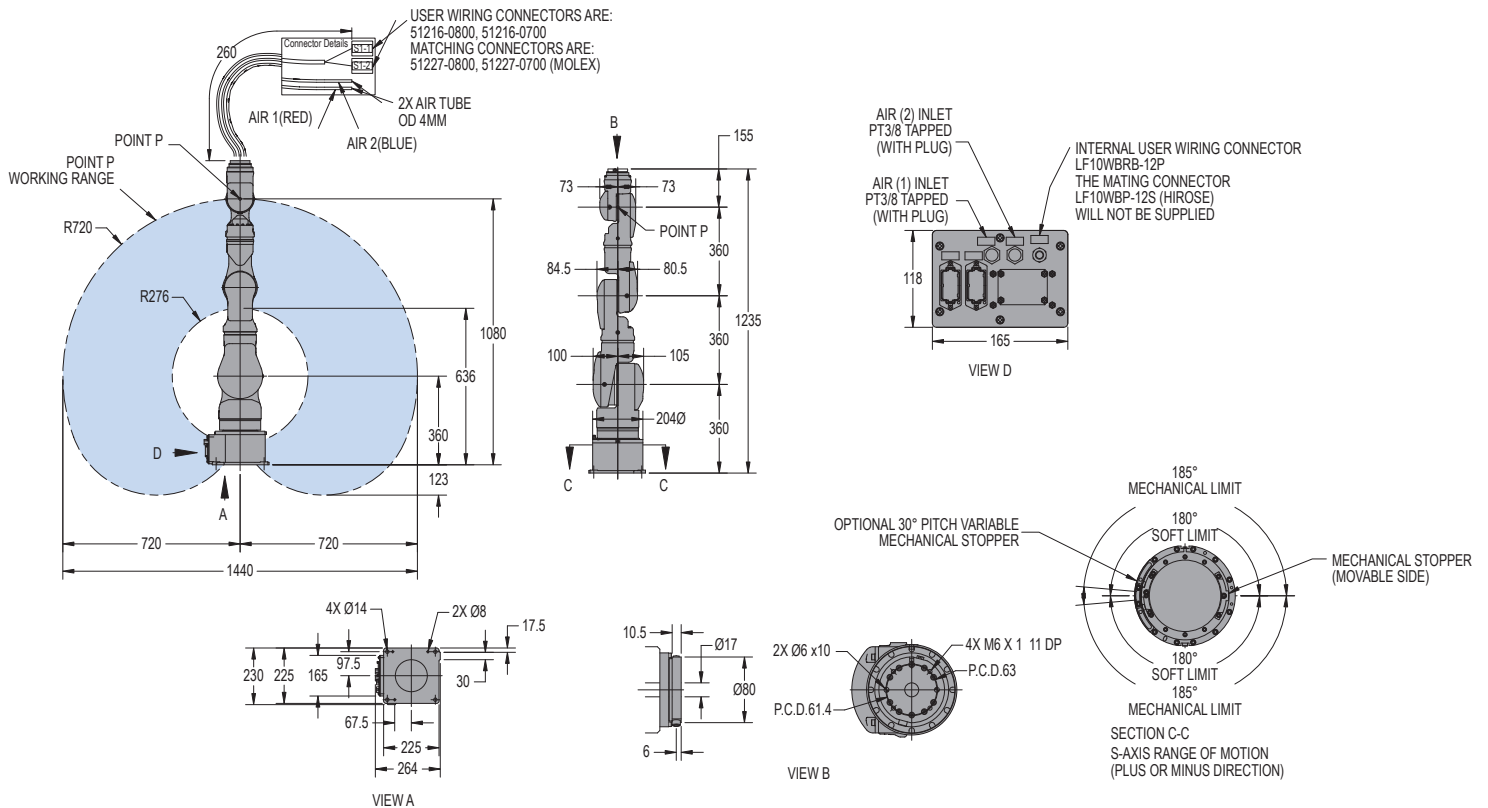

SIA10D SPECIFICATIONS

Structure	Articulated	
Mounting	Floor, Wall or Ceiling	
Controlled Axes	7	
Payload	10 kg (22.1 lbs)	
Vertical Reach	1,203 mm (47.4")	
Horizontal Reach	720 mm (28.3")	
Repeatability	±0.1 mm (±0.004")	
Maximum Motion Range	S-Axis (Turning/Sweep)	±180°
	L-Axis (Lower Arm)	±110°
	E-Axis (Elbow)	±170°
	U-Axis (Upper Arm)	±135°
	R-Axis	±180°
	B-Axis (Bend/Pitch/Yaw)	±110°
	T-Axis (Wrist Twist)	±180°
Maximum Speed	S-Axis	170°/s
	L-Axis	170°/s
	E-Axis	170°/s
	U-Axis	170°/s
	R-Axis	200°/s
	B-Axis	200°/s
	T-Axis	400°/s
Approximate Mass	60 kg (132.3 lb)	
Power Rating	1.5 kVA	
Allowable Moment	R-Axis	31.4 N · m
	B-Axis	31.4 N · m
	T-Axis	19.6 N · m
Allowable Moment of Inertia	R-Axis	1 kg · m ²
	B-Axis	1 kg · m ²
	T-Axis	0.4 kg · m ²
Protection Class	Standard	Not rated
	XP Version* (option)	IP50 base; IP64 body; IP67 wrist**

* XP Version: Yaskawa Motoman's eXtra Protection package
** Through-hole wrist must be sealed

DX100 CONTROLLER SPECIFICATIONS†

Dimensions (mm)	800 (w) x 1,000 (h) x 650 (d) (31.5" x 39.4" x 25.6")
Approximate Mass	250 kg max. (551.3 lbs)
Cooling System	Indirect cooling
Ambient Temperature	During operation: 0° to 45° C (32° to 113° F) During transit and storage: -10° to 60° C (14° to 140° F)
Relative Humidity	90% max. non-condensing
Primary Power Requirements	3-phase, 240/480/575 VAC at 50/60 Hz
Digital I/O	Standard I/O: 40 inputs/40 outputs consisting of 16 system inputs/ NPN-Standard 16 system outputs, 24 user inputs/24 user outputs PNP-Optional 32 Transistor Outputs; 8 Relay Outputs Max. I/O (optional): 2,048 inputs and 2,048 outputs
Position Feedback	By absolute encoder
Program Memory	JOB: 200,000 steps, 10,000 instructions CIO Ladder Standard: 15,000 steps Expanded: 20,000 steps
Pendant Dim. (mm)	169 (w) x 314.5 (h) x 50 (d) (6.7" x 12.4" x 2")
Pendant Weight	.998 kg (2.2 lbs)
Interface	One Compact Flash slot; One USB Port (1.1)
Pendant Playback Buttons	Teach/Play/Remote Keyswitch selector Servo On, Start, Hold, and Emergency Stop Buttons
Programming Language	INFORM III, menu-driven programming
Maintenance Functions	Displays troubleshooting for alarms, predicts reducer wear
Number of Robots/Axes	Up to 8 robots, 72 axes
Multi Tasking	Up to 16 concurrent jobs, 4 system jobs
Fieldbus	DeviceNet Master/Slave, AB RIO, Profibus, Interbus-S, M-Net, CC Link, EtherNet IP/Slave
Ethernet	10 Base T/100 Base TX
Safety	Dual-channel Emergency Stop Pushbuttons, 3-position Enable Switch, Manual Brake Release Meets ANSI/RIA R15.06-1999, ANSI/RIA/ISO 10218-1-2007 and CSA Z434-03

† See DX100 Controller data sheet (DS-399) for complete specifications

www.motoman.com

YASKAWA AMERICA, INC. ■ MOTOMAN ROBOTICS DIVISION
100 AUTOMATION WAY, MIAMISBURG, OHIO 45342
TEL: 937.847.6200 ■ FAX: 937.847.6277

YASKAWA
MOTOMAN ROBOTICS

TECHNICAL SPECIFICATIONS SUBJECT TO CHANGE WITHOUT NOTICE
DS-421-E ©2014 YASKAWA AMERICA, INC. MARCH 2014

MOTOMAN IS A REGISTERED TRADEMARK
WINDOWS IS A REGISTERED TRADEMARK OF MICROSOFT
ALL OTHER MARKS ARE THE TRADEMARKS AND
REGISTERED TRADEMARKS OF YASKAWA AMERICA, INC.