

# Angle Models

# Tensor ST

## ETV ST

- ETV ST right angle tools are ideal for hand-held and fixtured applications.
- Torque range from 1 to 4000 Nm.
- Tensor ST offers:
  - Extremely high productivity.
  - Ergonomic design.
  - Excellent operator feedback.
- The ETV ST ATEX tools are certified to be used in environments with hazardous gases and liquids.



ETV ST

Model	Square drive in	Torque range		Speed r/min	Weight		Length mm	CS distance mm	Height mm	Ordering No.
		Nm	ft lb		kg	lb				
<b>ETV ST31</b>										
ETV ST31-05-10	3/8	1-5	0.7-3.6	2390	1.0	2.2	381	11	39	8433 2011 21
ETV ST31-10-10	3/8	3-12	2.2-8.8	1020	1.0	2.2	381	11	39	8433 2013 66
ETV ST31-15-10	3/8	5-15	3.6-10	755	1.0	2.2	381	11	39	8433 2015 98
ETV ST31-20-10	3/8	5-22	3.7-16.1	545	1.2	2.6	415	14	42	8433 2017 10
<b>ETV ST31 Female Hex</b>										
ETV ST31-05-I06-QC	–	1-5	0.7-3.6	2390	1.0	2.2	381	11	39	8433 2011 95
ETV ST31-10-I06-QC	–	3-12	2.2-8.8	1020	1.0	2.2	381	11	39	8433 2014 21
<b>ETV ST61</b>										
ETV ST61-28-10	3/8	6-29	4-21	1450	1.3	2.9	440	14	42	8433 2021 76
ETV ST61-30-10	3/8	7-35	5-25	1090	1.3	2.9	440	15.5	42	8433 2023 92
ETV ST61-40-10	3/8	8-40	6-29	1090	1.5	3.3	454	18	47	8433 2027 85
ETV ST61-50-10	3/8	10-55	7-40	655	1.5	3.3	454	18	47	8433 2031 58
ETV ST61-70-13	1/2	15-80	10-58	475	2.0	4.5	466	20	58	8433 2035 30
ETV ST61-100-13	1/2	20-100	15-80	350	2.5	5.5	502	22.5	60	8433 2039 02
ETV ST61-150-13	1/2	30-160	22-117	227	3.0	6.6	536	25.5	65	8433 2042 70
ETV ST61-180-13	1/2	35-180	26-133	190	3.0	6.6	536	25.5	65	8433 2045 53
ETV ST61-200-20	3/4	40-200	30-154	185	3.0	6.6	537	27	70	8433 2046 39
<b>ETV ST61 ATEX</b>										
ETV ST61-28-10-ATEX	3/8	6-29	4-21	1450	1.3	2.9	440	14	42	8433 2023 76
ETV ST61-40-10-ATEX	3/8	8-40	6-29	1090	1.5	3.3	454	18	47	8433 2030 85
ETV ST61-50-10-ATEX	3/8	10-55	7-40	655	1.5	3.3	454	18	47	8433 2034 98
ETV ST61-70-13-ATEX	1/2	15-80	10-58	475	2.0	4.5	466	20	58	8433 2037 90
ETV ST61-100-13-ATEX	1/2	20-100	15-80	350	2.5	5.5	502	22.5	60	8433 2041 42
ETV ST61-150-13-ATEX	1/2	30-160	22-117	230	3.0	6.6	536	25.5	65	8433 2045 20
ETV ST61-200-20-ATEX	3/4	40-200	30-154	185	3.0	6.6	537	27	70	8433 2048 49
<b>ETV ST61 Ball Retainer</b>										
ETV ST61-70-B13	1/2	15-80	10-58	475	2.0	4.5	466	20	60	8433 2036 93
ETV ST61-100-B13	1/2	20-100	15-80	350	2.5	5.5	502	22.5	58	8433 2040 70
ETV ST61-150-B13	1/2	30-160	22-117	230	3.0	6.6	536	25.5	65	8433 2043 62
ETV ST61-180-B13	1/2	35-180	26-133	190	3.0	6.6	536	25.5	65	8433 2045 61
<b>ETV ST61 Flush Socket</b>										
ETV ST61-30-FS	-	7-35	5-25	1090	1.3	2.9	440	16	32	8433 2025 50
ETV ST61-40-FS	-	8-40	6-29	1090	1.5	3.3	454	18	39	8433 2029 50
ETV ST61-50-FS	-	10-55	7-40	655	1.5	3.3	454	18	39	8433 2033 15
ETV ST61-70-FS	-	15-80	10-58	475	2.0	4.5	466	20	50	8433 2037 36
ETV ST61-100-FS	-	20-110	15-80	350	2.5	5.5	502	23	51	8433 2040 75
ETV ST61-150-FS	-	30-160	22-117	220	3.0	6.6	539	26	58	8433 2044 14
ETV ST61-180-FS	-	35-180	26-133	190	3.0	6.6	539	26	58	8433 2045 72
ETV ST61-200-FS	-	40-200	30-154	185	3.0	6.6	541	27	58	8433 2047 21

Continued...

## Tensor ST

## Angle Models

Model	Square drive in	Torque range		Speed r/min	Weight		Length mm	CS distance mm	Height mm	Ordering No.
		Nm	ft lb		kg	lb				
<b>ETV ST61 Hold &amp; Drive</b>										
ETV ST61-28-HAD	-	6-29	4-21	1450	1.9	4.2	463	18.3	62	8433 2023 21
ETV ST61-50-HAD	-	10-55	7-40	655	2.0	4.4	440	18.3	80	8433 2033 92
ETV ST61-100-HAD	-	20-100	15-80	350	2.6	5.7	504	23	71	8433 2038 36
ETV ST61-100-HAD-HD	-	20-100	15-80	350	2.6	5.7	539	26	80	8433 2038 35
ETV ST61-120-HAD	-	30-130	22-100	350	2.6	5.5	540	26	80	8433 2041 53
ETV ST61-150-HAD	-	30-160	22-117	220	3.1	6.6	540	26	80	8433 2044 80
ETV ST61-180-HAD	-	35-180	26-133	190	3.1	6.6	540	26	80	8433 2045 80
ETV ST61-200-HAD	-	40-200	30-154	185	3.1	6.6	541	26	80	8433 2048 27
<b>ETV ST61 with Barcode Scanner</b>										
ETV ST61-30-10-BCR	3/8	7-35	5-25	1090	1.4	3.2	440	15.5	42	8433 2026 66
ETV ST61-50-10-BCR	3/8	10-55	7-40	655	1.6	3.6	454	18	47	8433 2034 67
<b>ETV ST81</b>										
ETV ST81-50-10	3/8	16-55	12-40	1090	1.8	3.9	473	18	48	8433 2051 55
ETV ST81-70-13	1/2	20-80	15-58	790	2.3	5.0	485	20	58	8433 2053 48
ETV ST81-100-13	1/2	20-100	15-80	540	2.7	5.9	522	22.5	60	8433 2056 82
ETV ST81-150-13	1/2	30-160	22-117	380	3.2	7.0	555	26	65	8433 2060 12
ETV ST81-180-13	1/2	35-180	26-133	310	3.2	7.0	555	26	65	8433 2062 31
ETV ST81-200-20	3/4	40-200	30-154	300	3.2	7.0	556	27	70	8433 2063 42
<b>ETV ST81 Ball Retainer</b>										
ETV ST81-70-B13	1/2	20-80	15-58	790	2.3	5.0	485	20	58	8433 2054 62
ETV ST81-100-B13	1/2	20-100	15-80	540	2.7	5.9	522	22.5	60	8433 2058 24
ETV ST81-150-B13	1/2	30-160	22-117	380	3.3	7.0	555	25.5	65	8433 2060 97
ETV ST81-180-B13	1/2	35-180	26-133	310	3.2	7.0	555	25.5	65	8433 2062 43
<b>ETV ST81 Flush Socket</b>										
ETV ST81-100-FS	-	20-100	15-80	540	2.7	5.9	522	23	51	8433 2058 68
ETV ST81-180-FS	-	35-180	26-133	310	3.2	7.0	555	26	58	8433 2062 50
ETV ST81-200-FS	-	40-200	30-154	300	3.2	7.0	557	28	58	8433 2064 59
<b>ETV ST81 Hold &amp; Drive</b>										
ETV ST81-50-HAD	-	16-55	12-40	1090	2.3	5.0	473	18.5	62	8433 2052 80
ETV ST81-100-HAD	-	20-100	15-80	665	2.6	5.7	542	23	71	8433 2056 36
ETV ST81-100-HAD-HD	-	20-100	15-80	665	2.7	5.9	542	26	80	8433 2056 35
ETV ST81-120-HAD	-	30-130	22-100	540	2.8	6.0	560	26	80	8433 2058 65
ETV ST81-150-HAD	-	30-160	22-117	365	3.3	7.0	560	26	80	8433 2061 81
ETV ST81-180-HAD	-	35-180	26-133	310	3.3	7.0	560	26	80	8433 2062 60
ETV ST81-200-HAD	-	40-200	30-154	300	3.3	7.0	561	28	81	8433 2065 09
<b>ETV ST101</b>										
ETV ST101-100-13	1/2	20-100	15-74	920	4.2	9.3	572	22.5	44	8433 2080 10
ETV ST101-180-13	1/2	50-180	37-133	575	4.2	9.3	600	25.3	47	8433 2080 52
ETV ST101-200-20	3/4	50-200	37-147	485	4.4	9.7	602	27.5	47	8433 2080 92
ETV ST101-270-20	3/4	65-270	48-199	380	7.3	16.1	672	32.9	62	8433 2081 23
ETV ST101-370-20	3/4	90-370	66-273	280	7.3	16.1	672	32.9	62	8433 2082 26
ETV ST101-450-20	3/4	110-450	81-332	230	10.6	23.4	715	54.0	76	8433 2082 81
ETV ST101-600-25	1	150-600	111-443	151	10.6	23.4	715	54.0	76	8433 2083 56
<b>ETV ST101 Fan</b>										
ETV ST101-100-13-F	1/2	20-100	15-74	920	4.2	9.3	572	23	44	8433 2080 30
ETV ST101-180-13-F	1/2	50-180	37-133	575	4.2	9.3	600	25	47	8433 2080 63
ETV ST101-200-20-F	3/4	50-200	37-147	485	4.4	9.7	602	28	47	8433 2080 93
ETV ST101-270-20-F	3/4	65-270	48-199	380	7.3	16.1	672	33	62	8433 2081 45
ETV ST101-370-20-F	3/4	90-370	66-273	280	7.3	16.1	672	33	62	8433 2082 48
ETV ST101-450-20-F	3/4	110-450	81-332	230	10.6	23.4	715	54	76	8433 2082 90
ETV ST101-600-25-F	1	150-600	111-443	150	10.6	23.4	715	54	76	8433 2083 69
<b>ETV ST101 Torque Multiplier</b>										
ETV ST101-600-TM	3/4	150-600	111-443	132	7.6	16.8	613	34	143	8433 2083 62
ETV ST101-1000-TM	1	250-1000	184-734	77	11.3	24.3	679	40	191	8433 2084 05
ETV ST101-1500-25-TM	1	325-1500	240-1100	23	12	26	625	43	257	8433 2084 65
ETV ST101-1500-38-TM	1 1/2	325-1500	240-1100	48	19	42	719	71	233	8433 2084 70
ETV ST101-2000-38-TM	1 1/2	500-2000	370-1475	35	19	42	719	71	231	8433 2084 80
ETV ST101-4000-38-TM	1 1/2	1000-4000	734-2950	21.8	21.5	47	710	71	350	8433 2084 90
<b>ETV ST101 Torque Multiplier/Fan</b>										
ETV ST101-600-TM-F	3/4	150-600	111-443	132	7.6	16.8	613	34	143	8433 2083 96
ETV ST101-1000-TM-F	1	250-1000	184-734	77	11.3	24.3	679	40	191	8433 2084 10

# Straight Models

# Tensor ST

## ETD ST

- ETD ST inline tools.
- Torque range from 1 to 4000 Nm.
- Tensor ST offers:
  - Extremely high productivity.
  - Ergonomic design.
  - Excellent operator feedback.



ETD ST

Model	Square drive in	Torque range		Speed r/min	Weight		Length mm	CS distance mm	Spline/ Mounting	Ordering No.
		Nm	ft lb		kg	lb				
<b>ETD ST31</b>										
ETD ST31-05-10	3/8	1-5	1.1-3.6	2825	0.9	2.0	388	24	- / 1	8433 2112 42
ETD ST31-10-10	3/8	2-10	2.2-7.2	1200	1.1	2.4	388	24	- / 1	8433 2114 86
<b>ETD ST31 Telescopic</b>										
ETD ST31-05-10-T25	3/8	1-5	1.1-3.6	2825	0.9	2.0	437	24	- / 13	8433 2111 34
ETD ST31-10-10-T25	3/8	2-10	2.2-7.2	1200	1.1	2.4	437	24	- / 13	8433 2113 79
<b>ETD ST31 Ball Retainer Telescopic</b>										
ETD ST31-05-B10-T25	3/8	1-5	1.1-3.6	2825	1.1	2.4	437	24	- / 13	8433 2113 44
<b>ETD ST31 Female Hex</b>										
ETD ST31-05-I06	1/4	1-5	1.1-3.6	2825	0.9	2.0	350	24	- / 14	8433 2112 87
<b>ETD ST61</b>										
ETD ST61-15-10	3/8	4-16	3-12	2250	1.4	3.1	438	24	- / 1	8433 2120 91
ETD ST61-20-10	3/8	5-22	3.6-16	1700	1.4	3.1	438	24	- / 1	8433 2122 62
ETD ST61-30-10	3/8	6-35	4.4-25	1020	1.4	3.1	429	24	- / 1	8433 2125 06
ETD ST61-50-13	1/2	10-55	7.3-40	740	1.9	4.2	474	24	2 / 2	8433 2128 79
ETD ST61-70-13	1/2	15-80	12-58	505	2.3	5.0	491	26.5	2 / 2	8433 2132 51
ETD ST61-90-13	1/2	20-95	15-70	410	2.3	5.0	491	26.5	2 / 2	8433 2136 22
<b>ETD ST61 Telescopic</b>										
ETD ST61-15-10-T25	3/8	4-16	3-12	2250	1.5	3.3	477	24	2 / 2	8433 2120 43
ETD ST61-20-10-T25	3/8	5-20	3.6-15	1700	1.5	3.3	477	24	2 / 2	8433 2121 55
ETD ST61-30-10-T25	3/8	6-35	4.4-25	1020	1.5	3.3	468	24	2 / 2	8433 2123 80
ETD ST61-50-13-T25	1/2	10-55	7.3-40	740	2.1	4.6	501	24	3 / 5	8433 2127 54
ETD ST61-70-13-T25	1/2	15-80	12-58	505	2.4	5.4	518	26.5	3 / 5	8433 2131 27
ETD ST61-90-13-T25	1/2	20-95	15-70	410	2.4	5.4	518	26.5	3 / 5	8433 2134 99
ETD ST61-120-13-T25	1/2	25-125	19-95	305	2.4	5.4	518	26.5	3 / 5	8433 2138 68
<b>ETD ST61 Female Hex</b>										
ETD ST61-15-I06	1/4	4-16	3-12	2250	1.4	3.1	430	24	- / 1	8433 2121 36
<b>ETD ST81</b>										
ETD ST81-30-10	3/8	10-30	7-22	1700	1.8	4.0	450	24	- / 1	8433 2151 93
ETD ST81-50-13	1/2	16-50	12-37	1230	2.1	4.6	493	24	2 / 2	8433 2153 34
ETD ST81-70-13	1/2	15-70	12-51	880	2.5	5.5	510	26.5	2 / 2	8433 2156 03
ETD ST81-90-13	1/2	20-95	15-70	675	2.5	5.5	510	26.5	2 / 2	8433 2158 14
ETD ST81-120-13	1/2	25-125	19-91	505	2.5	5.5	510	26.5	2 / 2	8433 2160 25
<b>ETD ST81 Telescopic</b>										
ETD ST81-70-13-T25	1/2	15-70	12-51	880	2.6	5.8	538	26.5	3 / 5	8433 2154 98
ETD ST81-90-13-T25	1/2	20-95	15-70	675	2.6	5.8	538	26.5	3 / 5	8433 2157 25
ETD ST81-120-13-T25	1/2	25-125	19-91	505	2.6	5.8	538	26.5	3 / 5	8433 2159 53

Continued...

## Tensor ST

## Straight Models

Model	Square drive in	Torque range		Speed r/min	Weight		Length mm	CS distance mm	Spline/ Mounting	Ordering No.
		Nm	ft lb		kg	lb				
<b>ETD ST101</b>										
ETD ST101-100-13	1/2	25-100	18-73	1043	3.2	7.0	631	30.5	-	8433 2179 00
ETD ST101-120-13	1/2	30-120	22-88	875	3.2	7.0	631	30.5	-	8433 2180 22
ETD ST101-150-20	3/4	30-150	22-109	685	4.3	9.3	706	33	-	8433 2181 36
ETD ST101-200-20	3/4	50-200	36-146	500	7.4	16.3	706	33	-	8433 2182 05
ETD ST101-300-20	3/4	70-300	51-221	345	7.4	16.3	706	33	-	8433 2182 70
ETD ST101-500-20	3/4	120-500	88-368	204	8.3	18.5	717	33	-	8433 2183 28
ETD ST101-750-25	1	150-750	109-553	143	9.1	20.3	681	45	-	8433 2184 40
ETD ST101-1000-25	1	250-1000	184-737	100	9.7	21.6	708	45	-	8433 2185 60
ETD ST101-1200-25-S	1	300-1200	220-885	81	12	26	787	47	7	8433 2196 10
<b>ETD ST101 Fan</b>										
ETD ST101-100-13-F	1/2	25-100	18-73	1043	3.2	7.0	631	30.5	-	8433 2179 05
ETD ST101-150-20-F	3/4	30-150	22-109	685	4.3	9.3	706	33	-	8433 2181 40
ETD ST101-200-20-F	3/4	50-200	36-146	500	7.4	16.3	706	33	-	8433 2182 10
ETD ST101-300-20-F	3/4	70-300	51-221	345	7.4	16.3	706	33	-	8433 2182 72
ETD ST101-500-20-F	3/4	120-500	88-368	204	8.3	18.5	717	33	-	8433 2183 30
ETD ST101-750-25-F	1	150-750	109-553	143	9.1	20.3	681	45	-	8433 2184 50
ETD ST101-1200-25-F	1	300-1200	220-885	81	12	26	787	47	-	8433 2186 10
ETD ST101-2000-38-F	1 1/2	500-2000	370-1475	48	17	37	742	68	-	8433 2187 22
ETD ST101-2000-38-S-F	1 1/2	500-2000	370-1475	48	17	37	742	68	8	8433 2197 22
ETD ST101-4000-38-F	1 1/2	1000-4000	735-2950	25	22	48	823	68	-	8433 2187 40
ETD ST101-4000-38-S-F	1 1/2	1000-4000	735-2950	25	22	48	823	68	8	8433 2197 40
<b>ETD ST101 Telescopic</b>										
ETD ST101-100-13-T25	1/2	25-100	18-73	1043	3.3	7.3	656	30.5	-	8433 2179 10
ETD ST101-120-13-T25	1/2	30-120	22-88	873	3.3	7.3	656	30.5	-	8433 2180 32
ETD ST101-150-20-T40	3/4	30-150	22-109	685	4.4	9.7	656	30.5	-	8433 2181 46
ETD ST101-200-20-T40	3/4	50-200	36-146	500	7.5	16.5	756	33	-	8433 2182 23
ETD ST101-300-20-T40	3/4	70-300	51-221	345	7.5	16.5	756	33	-	8433 2182 82
ETD ST101-500-20-T40	3/4	120-500	88-368	204	8.4	18.5	768	37	-	8433 2183 38
ETD ST101-750-25-T50	1	150-750	109-553	143	9.2	20.3	727	45	-	8433 2184 56
ETD ST101-1000-25-T50	1	250-1000	184-737	100	9.8	21.6	754	45	-	8433 2185 78
<b>ETD ST101 Telescopic Fan</b>										
ETD ST101-100-13-T25-F	1/2	25-100	18-73	1043	3.3	7.3	656	30.5	-	8433 2179 15
ETD ST101-120-13-T25-F	1/2	30-120	22-88	873	3.3	7.3	656	30.5	-	8433 2180 48
ETD ST101-150-20-T40-F	3/4	30-150	22-109	685	4.4	9.7	656	30.5	-	8433 2181 59
ETD ST101-200-20-T40-F	3/4	50-200	36-146	500	7.5	16.5	756	33	-	8433 2182 45
ETD ST101-300-20-T40-F	3/4	70-300	51-221	345	7.5	16.5	756	33	-	8433 2182 91
ETD ST101-500-20-T40-F	3/4	120-500	88-368	204	8.4	18.5	769	37	-	8433 2183 49
ETD ST101-750-25-T50-F	1	150-750	109-553	143	9.2	20.3	769	45	-	8433 2184 69
ETD ST101-1000-25-T50-F	1	250-1000	184-737	100	9.8	21.6	755	45	-	8433 2185 89
ETD ST101-1200-25-T50-F	1	300-1200	220-885	81	12	26	844	47	-	8433 2186 12
ETD ST101-1200-25-T50-S-F	1	300-1200	220-885	81	12	26	844	47	7	8433 2196 12
ETD ST101-2000-38-T50-F	1 1/2	500-2000	370-1475	48	17	37	840	68	-	8433 2187 20
ETD ST101-2000-38-T50-S-F	1 1/2	500-2000	370-1475	48	17	37	840	68	8	8433 2197 20
ETD ST101-4000-38-T50-F	1 1/2	1000-4000	735-2950	25	22	48	921	68	-	8433 2187 42
ETD ST101-4000-38-T50-S-F	1 1/2	1000-4000	735-2950	25	22	48	921	68	8	8433 2197 42

## Pistol Grip Models

## Tensor ST

### ETP ST

- ETP ST is a pistol grip model for hand-held applications.
- Torque range from 1 to 20 Nm.
- Female hex drive for bits.
- Low weight and ergonomic grip.
- Easy to access, reverse button.
- Operator friendly, feedback signals with sound and lights.



ETP ST

Model	Square drive in	Torque range		Speed r/min	Weight		Length mm	Height mm	Ordering No.
		Nm	ft lb		kg	lb			
<b>ETP ST32</b>									
ETP ST32-05-10	3/8	1-5	0.7-3.6	2820	0.75	1.7	197	179	8433 2211 03
ETP ST32-05-I06	-	1-5	0.7-3.6	2820	0.75	1.7	197	179	8433 2212 19
ETP ST32-10-10	3/8	3-11	2.2-8.0	1210	0.8	1.8	197	179	8433 2213 48
ETP ST32-10-I06	-	3-11	2.2-8.0	1210	0.8	1.8	197	179	8433 2214 63
ETP ST32-20-10	3/8	5-20	3.6-15.0	677	0.91	2	235	179	8433 2216 95
ETP ST32-20-I06	-	5-20	3.6-15.0	677	0.91	2	235	179	8433 2217 11
<b>ETP ST32 with Barcode Scanner</b>									
ETP ST32-05-I06BCR	-	1-5	0.7-3.7	2820	0.87	2	197	205	8433 2212 29
ETP ST32-10-I06BCR	-	3-11	2.2-8.0	1210	0.92	2.1	197	205	8433 2214 73
ETP ST32-20-I06BCR	-	5-20	3.6-15.0	677	1.03	2.3	237	205	8433 2217 26

## Pistol Grip Models

## Tensor ST Rev0

### ST REVO

- Unique and patented 360° swivel with transducer.
- Ultra-compact size improves access.
- Reduced weight means less need for fixtures.
- Display on tool gives direct feedback of tightening result.
- Program selection is made directly on tool.
- Ideal for handheld application or fixtures with reduced space.
- Torque range from 60-4000 Nm.



ETP ST Rev0

Model	Square drive in	Torque range		Speed r/min	Weight		Length mm	CS distance mm	Spline	Ordering No.
		Nm	ft lb		kg	lb				
<b>Model with fan</b>										
ETP ST101-200-20-F	3/4	60-200	45-145	396	5.2	11.5	303	32.5	3	8433 2302 02
ETP ST101-300-20-F	3/4	90-300	66-221	293	5.2	11.5	303	32.5	3	8433 2303 02
ETP ST101-500-20-F	3/4	150-500	110-365	186	5.9	13	334	33.5	4	8433 2305 02
ETP ST101-750-25-F	1	220-750	160-550	132	6.2	13.7	353	33.5	5	8433 2307 52
ETP ST101-1000-25-F	1	300-1000	220-735	99	6.4	14.1	364	33.5	5	8433 2310 02
ETP ST101-1500-25-F	1	450-1500	332-1106	47	8.8	19.4	402	43.5	9	8433 2321 52
ETP ST101-2000-38-F	1 1/2	600-2000	442-1475	38	11.5	25.4	454	48	7	8433 2322 02
ETP ST101-3000-38-F	1 1/2	900-3000	664-2212	24	14.8	33	476	59	8	8433 2323 02
ETP ST101-4000-38-F	1 1/2	1200-4000	885-2950	20	15	33	481	59	8	8433 2324 02

Reaction bar not included for ETP ST101. See accessory pages.

# Tensor ST Crowfoot

## IN-LINE CROWFOOT TOOLS

### Dimensions

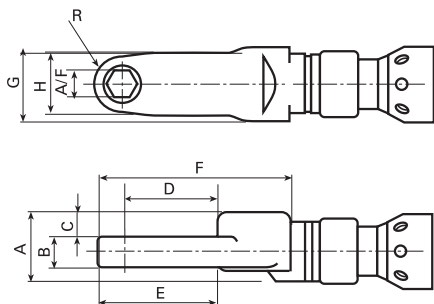

ETC ST

Model	Torque range		Speed r/min	Weight		Length mm	A/F mm	A mm	B mm	C mm	D mm	E mm	F mm	G mm	H mm	R mm	Ordering No.
	Nm	ft lb		kg	lb												
<b>ETC ST61</b>																	
ETC ST61-18-10-LI3	5-18	4-13	1429	1.9	4.2	523	10	34	15	12.5	36.7	59.2	82.2	35	22	10	8433 2311 11
ETC ST61-28-12-LI3	6-28	4-20	767	1.9	4.2	526	12	34	15	12.5	45.5	71	94	35	30	13	8433 2311 14
ETC ST61-90-21-LI3	20-90	14-66	316	4.1	9	684	21	46	20	16	74.5	44	158.8	64	40	20	8433 2311 44
ETC ST61-120-18-LI3	30-136	22-100	217	4.3	9.5	684	18	46	32	11.5	74.8	146.5	157.8	64	38	19	8433 2311 38
ETC ST61-100-19-LI3	26-110	19-81	250	4.2	9.2	678	19	46	28	13.5	69.6	74.9	151.6	64	36	18	8433 2311 35
ETC ST61-150-22-LI3	33-150	24-110	197	4.4	9.7	688	22	48	33	14	77.5	84	161.5	64	40	20	8433 2311 47

## OFFSET CROWFOOT TOOLS

### Dimensions

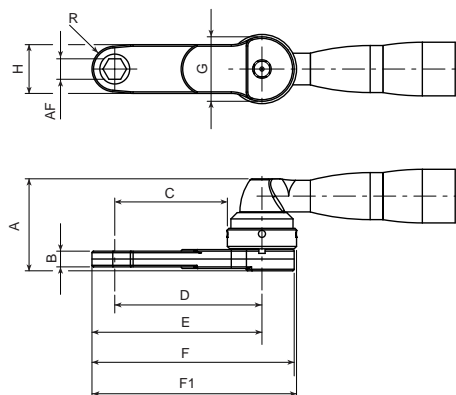

ETC ST

Model	Torque range		Speed r/min	Weight		Length mm	A/F mm	A mm	B mm	C mm	D mm	E mm	F mm	G mm	H mm	R mm	F1 mm	Ordering No.
	Nm	ft lb		kg	lb													
<b>ETC ST61</b>																		
ETC ST61-18-10-LO3	4-18	3-13	1450	1.5	3.3	469	10	60.3	15	14.55	32.8	42.8	57.8	36.5	22	10	61.1	8433 2310 09
ETC ST61-28-12-LO5	5-28	4-20	1090	2	4.4	533	12	69.5	15	62	84	97	117.5	44	30	13	119	8433 2310 12
ETC ST61-20-13-LO5	5-23	4-17	1090	1.7	3.7	534	13	57.5	10	71.6	93.6	108.1	128.6	44	31	14.5	130.1	8433 2310 15
ETC ST61-44-14-LO3	8-44	6-32	655	2	4.4	497	14	69.5	18	24.8	46.8	61.3	81.8	44	31	14.5	83.3	8433 2310 18
ETC ST61-64-16-LO3	12-64	9-47	475	2.5	5.5	512	16	77.8	24	27	51	66	88.5	48	30	15	90	8433 2310 27
ETC ST61-80-17-LO3	16-80	12-59	350	3.1	6.8	534	17	81	27	31.8	55.8	72.3	94.8	48	33	16.5	96.3	8433 2310 30
ETC ST61-90-21-LO5	24-90	17-66	227	4.2	9.2	664	21	89.4	20	100.8	132	152	178	62.5	40	20	183.3	8433 2310 45
ETC ST61-100-19-LO5	21-110	15-81	227	4.4	9.7	653	19	96.9	28	91.2	122.4	140.4	166.4	62.5	36	18	171.7	8433 2310 36
ETC ST61-140-18-LO3	28-140	20-103	190	4	8.8	595	18	96.9	32	32	63.2	82.2	108.2	62.5	38	19	113.5	8433 2310 39
ETC ST61-150-21-LO3	32-150	23-110	185	4	8.8	596	21	99.7	33	34.8	66	86	112	62.5	40	20	117.3	8433 2310 48
<b>ETC ST101</b>																		
ETC ST101-200-21-LO3	52-215	38-158	380	9.3	20.5	731	21	148.8	40	32.75	70.4	91.4	125.4	75.3	42	21	128.2	8433 2310 51
ETC ST101-200-22-LO3	52-200	38-147	380	9.3	20.5	738	22	139.8	37	38.55	76.2	98.7	132.7	75.3	45	22.5	135.5	8433 2310 57



## IN-LINE TUBE NUT TOOLS

### Dimensions

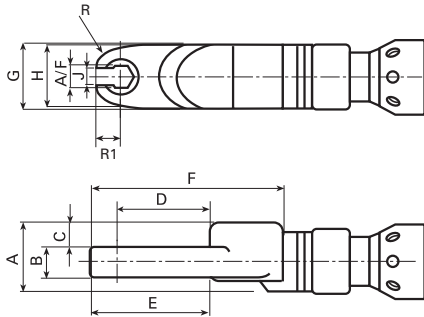

ETO ST

Model	Torque range		Speed r/min	Weight		Length mm	A/F mm	A mm	B mm	C mm	D mm	E mm	F mm	G mm	H mm	J mm	R mm	R1 mm	Ordering No.
	Nm	ft lb		kg	lb														
<b>ETO ST61</b>																			
ETO ST61-18-10-LI3	5-18	3.6-13	1278	1.8	4	522	10	34	11	14.5	34.1	31.1	81.5	35	38	8	11.9	15	8433 2311 68
ETO ST61-20-10-LI3	5-20	3.7-14.7	1278	1.9	4.2	519	10	34	14	13	31.9	29.7	78.6	35	38	8	11.2	14	8433 2311 64
ETO ST61-28-12-LI3	6-28	4.4-20.6	767	2.3	5.1	558	12	43	11	17.5	43.7	29.3	96.5	40	50	10.4	15	31	8433 2311 77
ETO ST61-30-12-LI3	6-33	4.4-24.3	772	2.3	5.1	544	12	43	18	14	34.3	31.4	83	40	40	10.4	12.4	25	8433 2311 74
ETO ST61-35-16-LI3	6-35	4.4-25.8	761	2.5	5.5	578	16	46	11	20.8	52	47.3	113.7	45	55	12.5	17.2	32	8433 2311 83
ETO ST61-60-19-LI3	15-60	11-44	371	3.6	7.9	638	19	46	18	17	49.3	44.6	111	45	59	14	17.2	32	8433 2311 86
ETO ST61-80-19-LI3	21-80	15-59	267	4.1	9	662	19	46	18	17	53.8	38.8	137.2	64	59	17	20.1	32	8433 2311 92
ETO ST61-100-21-LI3	21-100	15.5-73.7	267	4.4	9.7	674	21	46	20	16	64.4	56.5	148.9	64	76	18	22.3	32	8433 2311 95
<b>ETO ST81</b>																			
ETO ST81-100-24-LI3	39-110	28-81	240	4.6	10.1	706	24	46	20	16	71.3	50.6	160.4	64	77	20.5	24.6	33	8433 2311 98

## OFFSET TUBE NUT TOOLS

### Dimensions

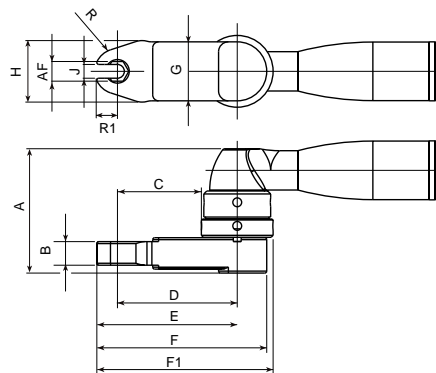

ETO ST

Model	Torque range		Speed r/min	Weight		Length mm	A/F mm	A mm	B mm	C mm	D mm	E mm	F mm	G mm	H mm	J mm	R1 mm	R mm	F1 mm	Ordering No.
	Nm	ft lb		kg	lb															
<b>ETO ST61</b>																				
ETO ST61-18-12-LO3	5-18	3.7-13.2	1090	1.6	3.5	470	12	64	11	9.4	31.4	43.8	64.3	44	38	8.5	12.4	16	65.8	8433 2310 78
ETO ST61-20-12-LO3	5-20	3.7-14.7	1450	1.6	3.5	466	12	64	14	7	29	40.2	60.7	44	38	8	11.2	14	62.2	8433 2310 72
ETO ST61-28-13-LO3	6-28	4.4-20.6	1090	1.9	4.2	488	13	65	11	12.8	36.8	51.8	74.3	48	50	10.4	15	31	75.8	8433 2310 84
ETO ST61-30-13-LO5	7-33	5.2-24.3	655	2.1	4.6	524	13	72.5	18	53.3	75.3	87.7	108.2	44	40	10.4	12.4	25	109.7	8433 2310 81
ETO ST61-50-17-LO5	10-50	7.3-37	475	2.8	6.2	552	17	80	18	66.8	90.8	105.8	128.3	48	50	12	15	31	129.8	8433 2310 87
ETO ST61-55-21-LO3	11-55	8.1-40.5	475	2.7	5.9	515	21	73.8	12	18	49.2	69.3	96.8	62.5	59	16	20.1	32	100.6	8433 2310 93
ETO ST61-100-21-LO3	23-100	17-74	227	4.4	9.7	588	21	97.8	20	20.6	54.6	76.9	110.9	75.3	76	18	22.3	32	114.6	8433 2310 99
ETO ST61-100-27-LO3	23-100	17-74	227	4.5	9.9	597	27	95.8	20	23.2	60	84.6	118.6	73.5	77	20.5	24.6	33	121.4	8433 2311 02