

# E Series Tool Cable Options



Step 1: Select a tool whip for the tool model

Step 2: Select an extension for the selected whip number

Note: All Hi-Flex cables have an 8cm (3in) minimum bend radius

Choose Your Cable

Fits  
E12  
Lever Tools



20C1046[##] High Flex E1 Lever Whip,  
[##] = 01, 03, 05, 07 or 10 meters

Fits E23-34  
Lever Tools

E02-34 Pistols  
(Bottom Exit)

Lightweight  
E3 Whip

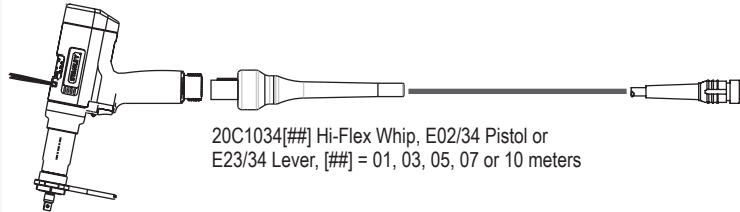

20C1034[##] Hi-Flex Whip, E02/34 Pistol or  
E23/34 Lever, [##] = 01, 03, 05, 07 or 10 meters

Fits  
E23-55, \*E12  
Lever Tools

E02-34 Pistols  
(Bottom Exit)

Standard  
E5 Whip

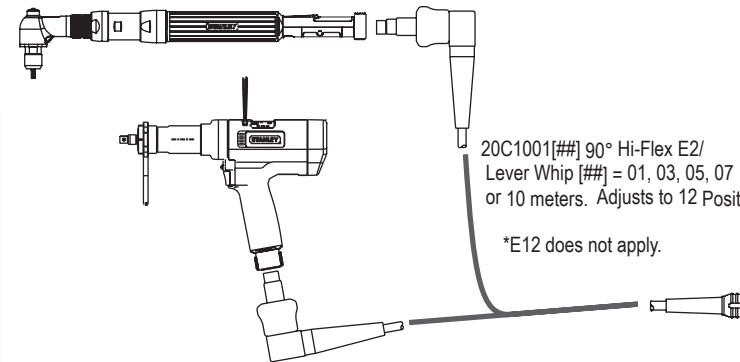

20C1001[##] 90° Hi-Flex E2/  
Lever Whip [##] = 01, 03, 05, 07  
or 10 meters. Adjusts to 12 Positions @ 30°  
  
\*E12 does not apply.

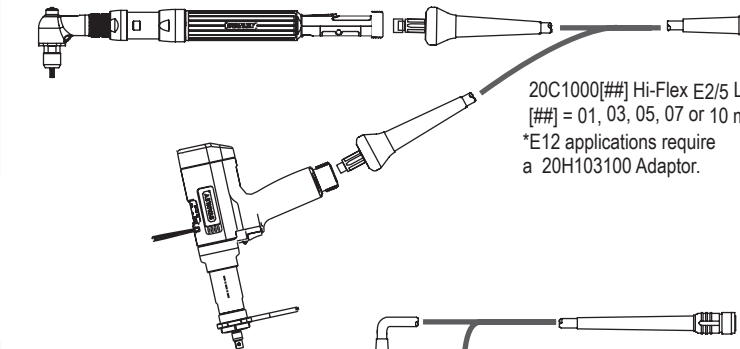

20C1000[##] Hi-Flex E2/5 Lever Whip,  
[##] = 01, 03, 05, 07 or 10 meters  
\*E12 applications require  
a 20H103100 Adaptor.

Fits  
E02-34 Pistol  
(Top Exit)

E23-55  
Moving  
Fixtured Motors

Standard  
E5 Whip

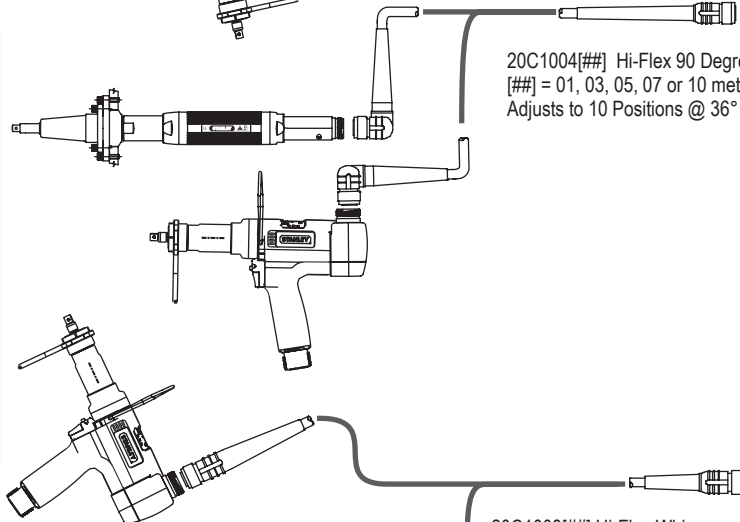

20C1004[##] Hi-Flex 90 Degree Whip  
[##] = 01, 03, 05, 07 or 10 meters @ Tool  
Adjusts to 10 Positions @ 36°

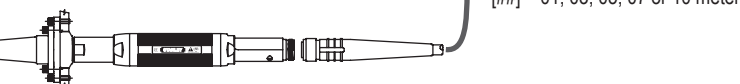

20C1003[##] Hi-Flex Whip  
[##] = 01, 03, 05, 07 or 10 meters



20C1011[##] 90 Degree  
Jamnut Extension  
[##] = 05, 10,  
or 20 meters

20C1002[##] Jamnut  
Extension [##] =  
05, 10, or 20 meters

**NOTE:**  
Jamnut cables  
have connectors  
that can be fixed to bulkheads.