

# IRB 4400

## Industrial Robot



IRB 4400 is an extremely fast, compact robot for medium to heavy handling. It has exceptional all-round capabilities which makes it suitable for a variety of manufacturing applications. The load capacity of 60 kg at very high speeds usually permits handling of two parts at a time. IRB 4400 is an extremely fast, compact robot for medium to heavy handling.

### Fast, compact and versatile industrial robot

IRB 4400 is a rigid, well-balanced design and patented TrueMove™ function provide smooth and fast movement throughout the entire working range. This ensures very high quality in applications such as cutting. Rapid maneuverability makes the IRB 4400 perfectly matched for applications where speed and flexibility are important. The compact design and protected versions enables use in situations where conventional robots cannot work, such as foundry and spraying applications. The Foundry Plus 2 version is IP 67 protected and can be washed with high pressure steam, which makes it ideal for use in harsh environments.

### Reliability and economy

The robust, rigid construction means long intervals between routine maintenance. Well-balanced steel arms with double bearing joints, a torque-strut on axis 2 and use of maintenance-free gearboxes and cabling also contribute to the very high levels of reliability.

The drive train is optimised to give high torque with the lowest power consumption for economic operation.

### Extensive communication for easy integration

The extensive communication capabilities include serial links, network interfaces, PLC, remote I/O and field bus interfaces. This makes for easy integration in small manufacturing stations as well as large scale factory automation systems.

### Main Applications

- Cutting and deburring
- Grinding and polishing
- Machine tending
- Material handling

## Specification

Robot versions	Reach	Payload	Standard	Foundry Plus 2
IRB 4400/60	1.96 m	60 kg	Yes	Yes
IRB 4400L/10	2.53m	10 kg	Yes	Yes

## Supplementary load

on axis 2	35 kg
on axis 3	15 kg
on axis 4	0-5 kg

## Number of axes

Robot manipulator	6
External devices	6
Integrated signal supply	23 signals and 10 power on upper arm
Integrated air supply	Max. 8 bar on upper arm
IRC5 Controller variants	Single cabinet, Dual cabinet

## Performance

Position repeatability	0.19 mm
Path repeatability at 1.6 m/s	0.56 mm

## Axis movements

### Working range

Axis	Working range	Maximum speed
1, C Rotation	Axis 1 + 165 to - 165	Axis 1 150°/s
2, B Arm	Axis 2 + 96 to - 70	Axis 2 120°/s
3, A Arm	Axis 3 + 65 to - 60	Axis 3 120°/s
4, D Wrist	Axis 4 +200 to - 200	Axis 4 225°/s
4, Option	Unlimited	
5, E Bend	Axis 5 +120 to - 120	Axis 5 250°/s
6, P Turn	Axis 6 + 400 to - 400	Axis 6 330°/s
6, Option	Unlimited	

## Electrical Connections

Supply voltage	200-600 V, 50/60 Hz
Rated power	
Transformer rating	7.8 kVA

## Physical

Robot mounting	
IRB 4400	Floor
Dimensions	
Robot base	920 x 640 mm
Weight	
Robot	1040 kg

## Environment

Ambient temperature	
Manipulator	5 – 45°C
Relative humidity	Max. 95%
Degree of protection	
Standard version	IP 54
Foundry Plus 2	IP 67 and high pressure steam washable
Noise level	Max. 70 dB (A)
Safety	Double circuits with supervision, emergency stops and safety functions, 3-position enable device
Emmission	EMC/EMI-shielded

Data and dimensions may be changed without notice

## Working range and load diagram

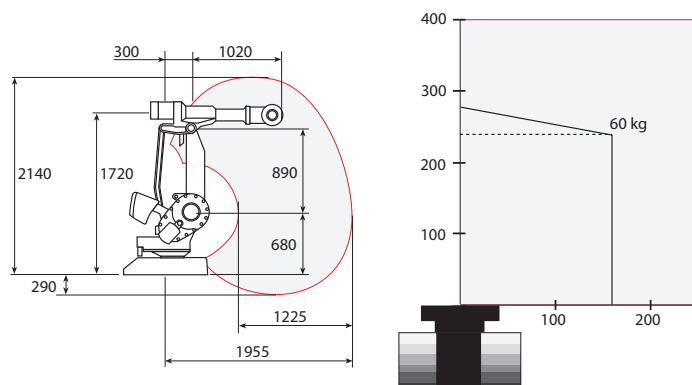

ABB AB Robotics  
Hydrovägen 10 SE-721 36  
Västerås, Sweden  
Phone: +46 21325000

ABB Engineering (Shanghai) Ltd.  
No. 4528, Kangxin Highway,  
Pudong New District,  
Shanghai, 201319, China  
Phone: +86 21 6105 6666

We reserve the right to make technical changes or modify the contents of this document without prior notice. With regard to purchase orders, the agreed particulars shall prevail. ABB does not accept any responsibility whatsoever for potential errors or possible lack of information in this document.

We reserve all rights in this document and in the subject matter and illustrations contained therein. Any reproduction, disclosure to third parties or utilization of its contents – in whole or in parts – is forbidden without prior written consent of ABB. Copyright© 2017 ABB  
All rights reserved