

# MH180-120

MATERIAL HANDLING | MACHINE TENDING | PRESS TENDING

## KEY BENEFITS

Small mounting surface and minimum interference radius save valuable floorspace

Optimized robot design with increased speed reduces cycle time

Payload, moment and inertia ratings allow the robots to be used in a wide variety of applications

Slim wrist profile for high density spacing and for reaching into confined spaces

## SPECIFICATIONS

120 kg payload  
3,058 mm horizontal reach  
4,105 mm vertical reach  
±0.2 mm repeatability  
Floor mounted

## CONTROLLERS



DX200



FS100



MLX200

- Ideal for processing large parts. In many cell layouts, a long/extended reach robot can eliminate the need for an external track, reducing system cost and simplifying programming.
- Powerful six-axis handling robot features high-rigidity speed reducers and high-speed motion which reduce cycle times.
- High payload and increased moment and inertia ratings allows this robot to handle larger and heavier payloads.
- New, streamlined upper arm design features a slim wrist profile and reduces robot width by over 200 mm. This allows easier reach into confined spaces, improving application flexibility.
- New base design reduces robot interference radius to only 515 mm, the lowest in its class. This allows the robot to be mounted closer to machines and fixtures, making best use of valuable floorspace.
- New design removes the counterbalance from robot base. This reduces the mass of the arm, enabling higher acceleration, deceleration and speed.
- The required mounting surface is reduced by nearly 44%, saving valuable floor space and making the robot easier to apply.
- Up to 70% less power consumption during motion and 25% savings during idle periods compared to previous models.
- Cables and air lines are routed through robot base to upper arm to increase cable life, enhance safety and reduce teaching time.
- Cable installation tube in the base of the robot facilitates fieldbus routing to the robot upper arm and/or gripper.
- Pre-wired for servo gripper which allows a wider range of product handling.
- The MH180-120 has an IP67-rated wrist and an IP54 body standard. An XP (eXtra Protection) package that increases the body protection rating to IP65 is available.

# MH180-120 ROBOT

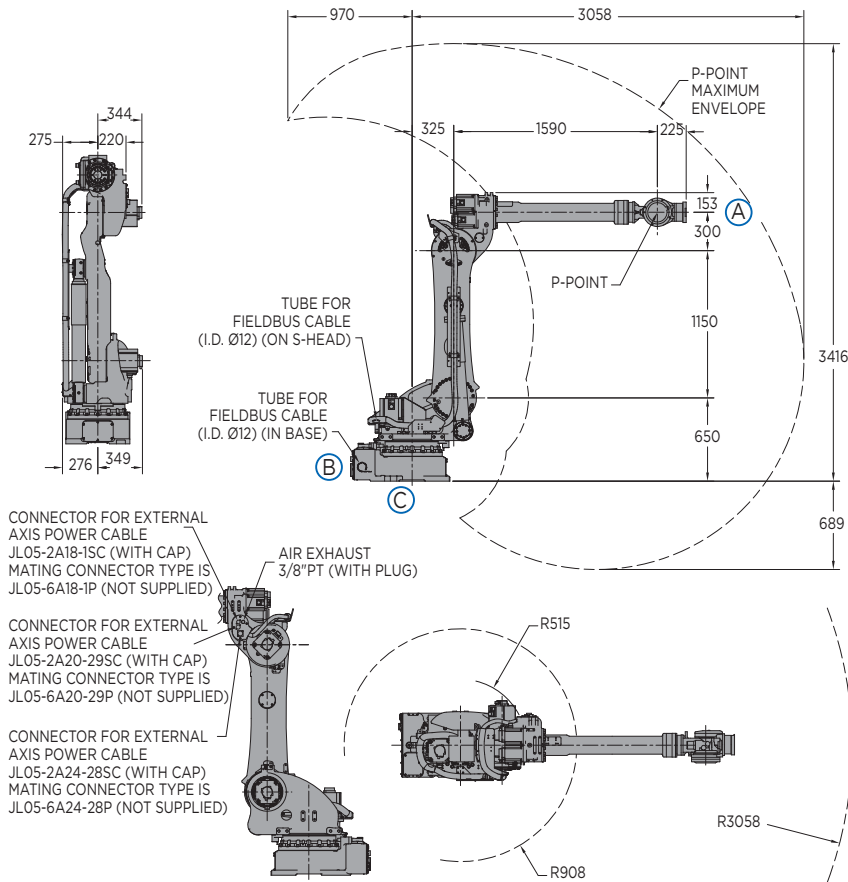

VIEW A

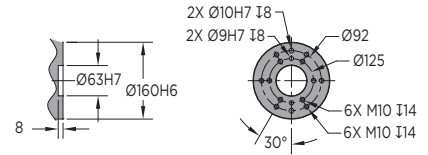

VIEW B

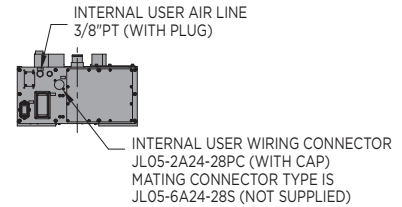

VIEW C

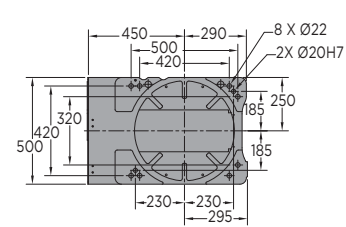

All dimensions are metric (mm) and for reference only.  
Request detailed drawings for all design/engineering requirements.

## SPECIFICATIONS: MH180-120

Axes	Maximum motion range [°]	Maximum speed [°/sec.]	Allowable moment [N•m]	Allowable moment of inertia [kg•m <sup>2</sup> ]	Controlled axes	6
S	±180	125	-	-	Maximum payload [kg]	120
L	+76/-60	115	-	-	Repeatability [mm]	±0.2
U	+90/-142	125	-	-	Horizontal reach [mm]	3,058
R	±360	182	883	79	Vertical reach [mm]	4,105
B	±130	175	883	79	Temperature [°C]	0 to +45
T	±360	265	520	40	Humidity [%]	20 - 80
					Weight [kg]	1,010
					Power supply, average [kVA]	5.0
					Internal I/O cable [conductors w/ ground]	24
					Internal air line [connections]	(1) 3/8"

Specifications for MH180-120 with XP package may be different.

## OPTIONS

- Extended length manipulator cables
- Robot risers and base plates
- External axis kits
- Wide variety of fieldbus cards
- Vision systems
- Robot base and upper arm I/O cables
- XP package and anti-corrosive paint

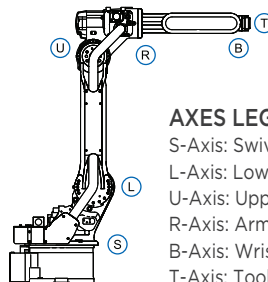

### AXES LEGEND

- S-Axis: Swivel Base
- L-Axis: Lower Arm
- U-Axis: Upper Arm
- R-Axis: Arm Roll
- B-Axis: Wrist Bend
- T-Axis: Tool Flange

Yaskawa America, Inc.  
Motoman Robotics Division

100 Automation Way  
Miamisburg, OH 45342  
Tel: 937.847.6200  
Fax: 937.847.6277

[motoman.com](http://motoman.com)

# YASKAWA