

# MPL800 II

## PALLETIZING

### KEY BENEFITS

High-speed, 4-axis palletizing robot with performance-driven design

High allowable moment of inertia handles unbalanced loads effectively

Highly reliable

### SPECIFICATIONS

800 kg maximum payload

3,024 mm vertical reach

3,159 mm horizontal reach

±0.5 mm repeatability

### CONTROLLERS



DX200



FS100



MLX200

- Highly versatile, this 4-axis robot is ideal for a variety of palletizing applications, order picking and other logistical tasks for end-of-line or distribution center automation.
- Extensive 3,024 mm vertical reach combined with 3,159 mm horizontal reach enables this robot to build 102 in. tall trailer-high loads on standard 48 in. x 40 in. pallet.
- Hollow wrist provides a wide range of wrist motion without interference.
- T-axis features high allowable moment of inertia; asymmetric loads are handled effectively without compromising speed or performance.
- Internally routed airlines and cables from base to the end-of-arm tool maximizes reliability.
- Cable installation tube in robot base facilitates fieldbus routing to the upper arm and/or gripper.
- Available with PalletSolver™, Yaskawa Motoman's operator-friendly palletizing software suite for fast and easy creation of palletizing patterns.
  - PalletSolver's offline pattern generation tool with intuitive graphical interface allows quick changeovers without halting production.
  - Highly customizable to each palletizing system.
  - Directly imports pallet patterns generated in widely-used TOPS® or CAPE software.

# MPL800 II ROBOT

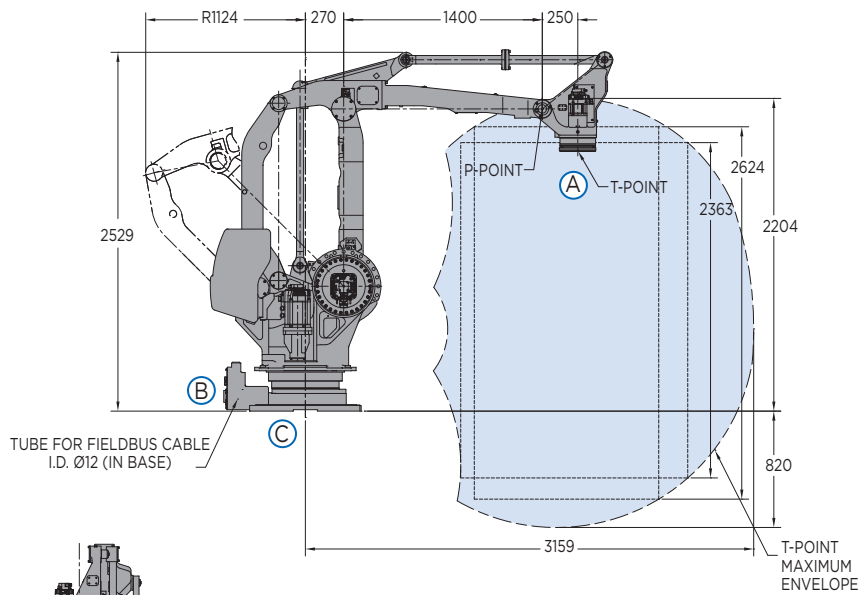

VIEW A

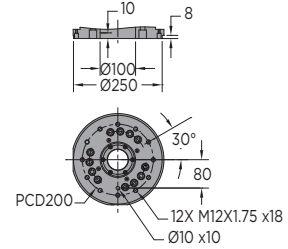

VIEW B

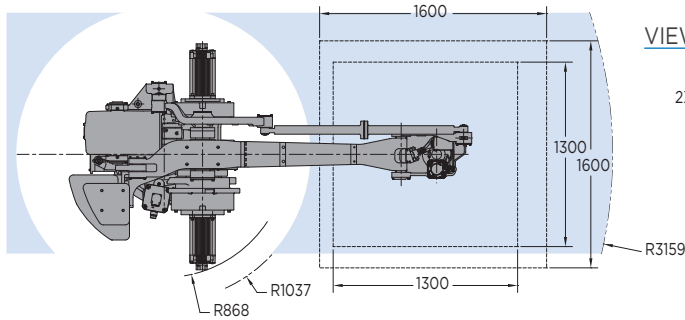
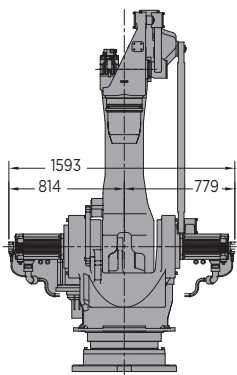
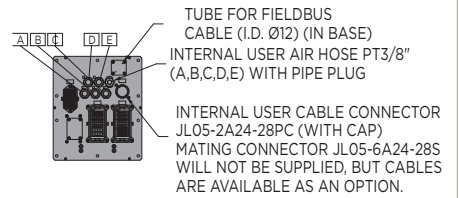

VIEW C

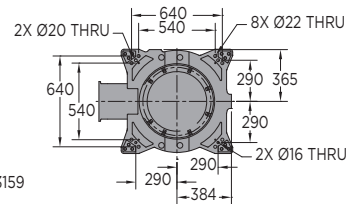

All dimensions are metric (mm) and for reference only.  
Request detailed drawings for all design/engineering requirements.

## SPECIFICATIONS

Axes	Maximum motion range [°]	Maximum speed [°/sec.]	Allowable moment [N•m]	Allowable moment of inertia [kg•m <sup>2</sup> ]	Controlled axes	4
S	±180	65	-	-	Maximum payload [kg]	800
L	+90/-45	65	-	-	Repeatability [mm]	±0.5
U	+15.5/-120	65	-	-	Horizontal reach [mm]	3,159
T	±360	125	-	550	Vertical reach [mm]	3,024
					Protection (IP rating)	IP54
					Weight [kg]	2,550
					Power requirements	3-phase; 240/480/575 VAC at 50/60 Hz
					Power rating [kVA]	8.0

## OPTIONS

- Extended length manipulator cables
- PalletSolver - revolutionary palletizing software
- MotoSight™ - easy to integrate vision software
- Robot risers and base plates
- Wide variety of fieldbus connectivity

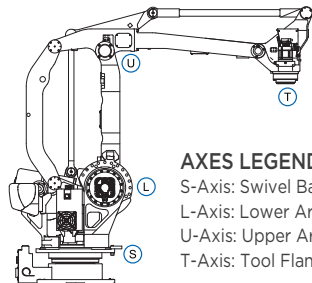

**AXES LEGEND**  
S-Axis: Swivel Base  
L-Axis: Lower Arm  
U-Axis: Upper Arm  
T-Axis: Tool Flange

Yaskawa America, Inc.  
Motoman Robotics Division

100 Automation Way  
Miamisburg, OH 45342  
Tel: 937.847.6200  
Fax: 937.847.6277

[motoman.com](http://motoman.com)

